

Performance Evaluation of Photo-Voltaic Fed Brushless Direct Current Motor For Agricultural Applications

A. Jawahar¹, S.Sasikanth²

¹*Department of Electrical and Electronics Engineering,
KL University, Guntur, 522502, India 0891jawahar@gmail.com*

²*Department of Electrical and Electronics Engineering,
KL University, Guntur, 522502, India*

Abstract

Solar water pumping system is a pro-active approach in agricultural applications. This paper presents modeling of Photo-voltaic (PV) panel, Maximum power point tracking (MPPT) controller considering hill climbing, perturb & observe algorithms, modeling of Brushless direct current (BLDC) motor. PV panel connected to load with and without MPPT controllers is simulated and results are presented. The performance of BLDC motor with variation of irradiance are presented.

Index Terms: BLDC (Brushless Direct Current) Motor, MPPT (Maximum power point tracker), PV (Photo-voltaic) cell.

Introduction

Solar Photovoltaic systems (SPV) have been in existence since many years. The PV systems are divided into two types namely OFF-GRID (Stand alone) Systems and ON-GRID (Grid-Connected system) based on application. In an OFF-Grid system, the power generated from the PV Arrays is utilized completely by the load while in ON-Grid system the power required by the load is delivered by PV panel and excess power can be given to the Grid.

There are two kinds of installation of PV panel namely fixed and rotating. Generally power from the PV Panel is not constant always; it varies with atmospheric conditions viz., irradiance and temperature. Hence, to extract maximum power from the PV array and supply it to the load, a controller circuit has to be present between PV panel and load. Generally the controller circuit is charge controller. Practically Charge controllers are of two types PWM and MPPT Type.

This paper presents an off-Grid solar pumping system with BLDC motor for agriculture applications. It deals with MPPT Charge controller for a fixed PV Panel. The Motors generally used for agricultural applications are AC Induction Motors [1]

and Conventional DC Motors. In recent years with exploration of new permanent magnet materials there is a sharp decline in their cost, which results in increased availability of BLDC motor. Hence Brushless DC Motors (BLDC) are also being used for domestic, commercial and agricultural applications.

The methodology used in this paper is

1. Modeling of PV Panel [2].
2. PV Panel connected to sensitive load with and without MPPT [4-6]
3. PV Panel connected to BLDC motor with MPPT [8-9].

Modeling of Photovoltaic Panel

The solar cell can be modeled as a silicon diode which produces voltage when light is illuminated on it. Solar cells are constant current sources and can be represented as shown in the Fig1

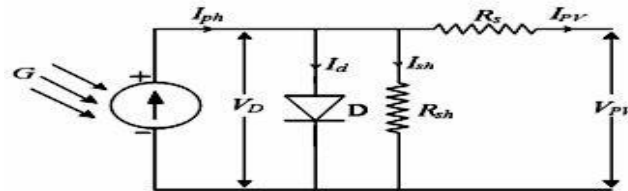

Figure 1: Mathematical Model of PV Cell

PV panel is modelled using mathematical equations (1)-(6) as given below

$$\text{The current from PV panel is given by } I_{pv} = I_{ph} - I_d - I_{sh} \text{ ----- (1)}$$

Where I_{pv} = Current from PV panel I_{ph} = Photo generated Current

I_d = Diode current I_{sh} = Shunt current

$$\text{The Photo generated current is given by } I_{ph} = G \times (I_{sc} + (K_i \times (T_{op} - T_{ref}))) \text{ ----- (2)}$$

Where G = Irradiation (w/m^2) I_{sc} = Short circuit Current

K_i = Temp.Coefficient of I_{sc} (2.2×10^{-23}) T_{op} = Operating Temperature in $^{\circ}\text{C}$

T_{ref} = Reference Temperature (25°C)

$$\text{The diode current is given by } I_d = I_s \times \left(e^{q \times \left(\frac{V_{pv} + I_{pv} \times R_s}{N_s \times n \times V_t \times C} \right)} - 1 \right) \text{ ----- (3)}$$

Where I_s = Saturation Current V_{pv} = PV Panel output voltage

R_s = Series resistance (0.01Ω) V_t = Thermal Voltage = $\left(\frac{K \times T_{op}}{q} \right)$

n = Ideality Factor (1-2) C = Total no. of Cells

N_s = No. of cells in series Q = Charge of an electron = $1.602 \times 10^{-19} \text{ C}$

K = Boltzmann Constant = 1.38×10^{-23}

The saturation current is given by $I_s = I_{rs} \times \left(\frac{T_{op}}{T_{ref}} \right) \times e^{\left(\frac{1}{T_{op}} - \frac{1}{T_{ref}} \right) \left(\frac{E_g \times q}{K \times n} \right)}$ ----- (4)

Where the reverse saturation current is given by

$$I_{rs} = \frac{I_{sc}}{e^{\left(\frac{q \times V_{oc}}{K \times C \times T_{op} \times n} \right)} - 1}$$
 ----- (5)

Where E_g = Energy Gap of PV material = 1.12ev

The shunt current is given by $I_{sh} = \left(\frac{V_{pv} + (I_{pv} \times R_s)}{R_{sh}} \right)$ ----- (6)

The number of cells to be connected to form an array is considered by taking a practical PV Panel electrical data Table 1. The I-V and P-V characteristics of the modeled PV panel conform to the manufacturer data.

Table 1: (Manufacturer Electrical data)

Maximum Power	252W
Voltage at Maximum Power	31V
Current at Maximum Power	8.1A
Open Circuit Voltage , Voc	38V
Short Circuit Current , Isc	8.95 A

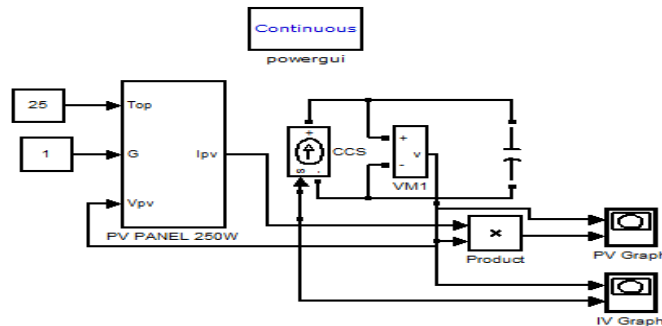

Figure 2: Simulink Model of Photovoltaic Panel

For instance, for a 250w PV panel as shown in the fig2. The I-V and P-V characteristics of the Panel for an Irradiance=1000w/m² & temp = 25°C is shown in the fig3.

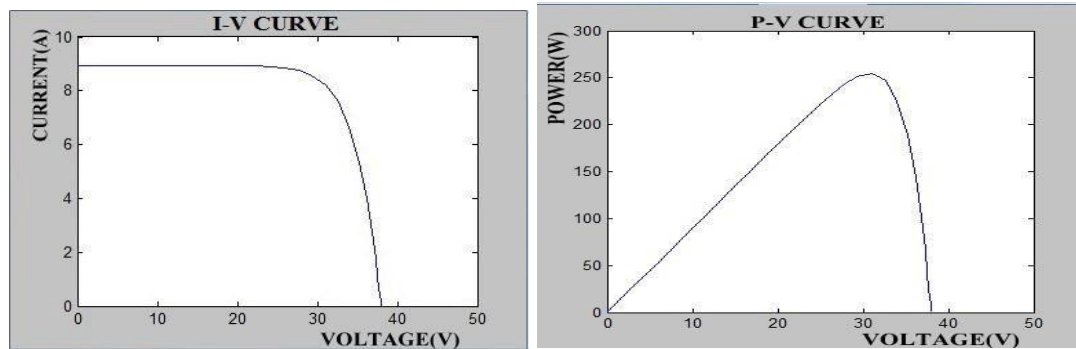

Figure 3: I-V and P-V curves of a PV panel

The specification of PV panel generally include open-circuit voltage (V_{oc}), short circuit current (I_{sc}), voltage corresponding maximum power (V_{mpp}). For a particular irradiance, maximum power is obtained only at one value. As an example, for a 250w panel with irradiance of 1000w/m^2 and Temperature of 25°c the maximum power obtained is at 31V as shown in the fig3. This is called voltage at maximum power point (V_{mpp}). Table II shows variation of V_{mpp} with changing irradiance.

MPPT (Maximum Power Point Tracking) Controller

MPPT Controller is dc-dc converter which can increase or decrease the output power for a given input as shown in the fig4. It is analogous to a transformer in AC circuits. The voltage can be changed by varying the duty ratio given to the switch in DC-DC Converter (Buck/Boost/Buck-Boost/Sepic/Cuk converters etc)

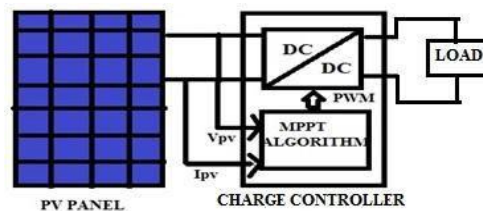

Figure 4: PV Panel connected to load with charge controller

A Technique called Pulse width modulation (PWM) is used in the process of increase/decrease of input voltage. The output voltage of a PV Panel is directly proportional to irradiance and inversely proportional to temperature. Maximum power from PV panel is obtained corresponding to a particular voltage (V_{mpp}). At that irradiance the voltage is set such that always V_{mpp} is maintained against the panel it is possible to extract maximum power from the PV array.

It is observed that from the I-V and P-V curves of a PV panel, V_{mpp} change with respect to irradiance. Tracking is essential to ensure constant voltage for constant irradiance. The DC-DC Converter [3] as shown in the fig5 considered here is a Boost

Converter. The values of „L“ & „C“ are calculated based on the input voltage and required output voltage.

The process of tracking the maximum power point with respect to changing irradiance and maintaining power at that point is the primary function of maximum power point tracker. Maximum power point tracker consist an algorithm to fix the duty ratio to be given to the DC-DC converter. As shown in the fig6 the algorithms take the samples of voltage, current from PV panel at instant and determine the duty cycle to be given to DC-DC Converter. The most commonly used algorithms are Perturb & observe algorithm and Hill climbing algorithm. [4-6] the simulink model of Hill climbing MPPT algorithm is shown in the fig7. Fig 8 & Fig9 gives the simulink model of PV panel connected to „R“ load with and without MPPT controller.

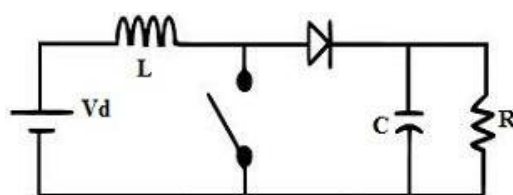

Figure 5: Boost converter

For a resistive Load connected to Boost converter the value of „L“ is given by the equation

$$L = \left(\frac{T_s \times V_o}{2 \times I_{ob}} \right) \times (D \times (1 - D)^2) \text{ ----- (7)}$$

The value of „C“ considered here is very large enough to maintain constant voltage at the load.

The Value of „L“ can be varied in accordance with input, output voltage and power
Where

L = Inductance value in Henry Ts = Switching frequency in Hz

Vo = Output voltage (V) D = Duty cycle or Duty ratio.

I_{ob}= Boundary current (A) I_{ob} determines whether output current is continuous or not

In Boost converter, inductor current and output current are equal. For any increase in load, than the maximum possible level results in increase in output current, the increase level of current cannot be provided by the source. Hence „L“ & „C“ determination is important. It is observed from the above that duty cycle is required for operation of DC-DC converter. The determination of duty cycle is accomplished with MPPT algorithms.

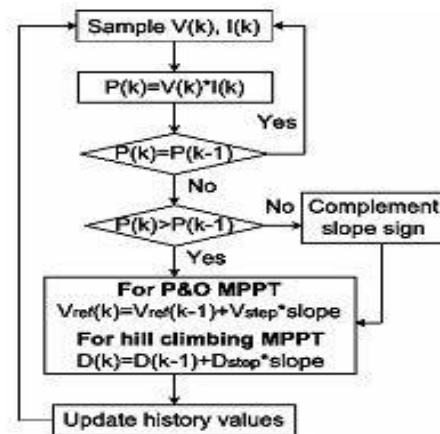

Figure 6: P & O, Hill climbing MPPT algorithms

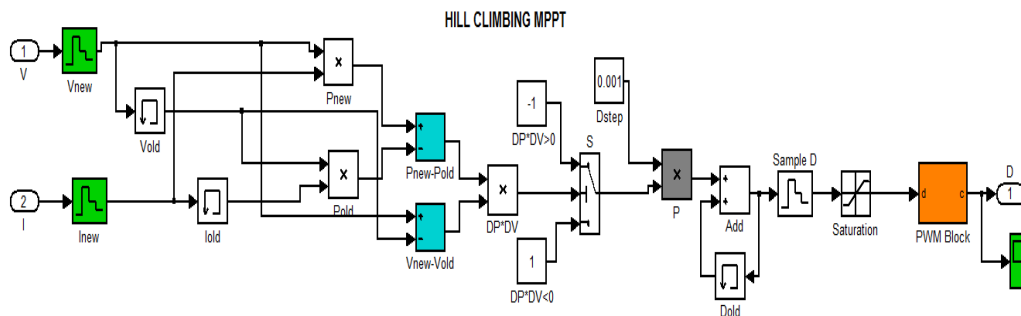

Figure 7: Hill Climbing MPPT Algorithm Simulink Model

Simulink Models of PV Panel Connected To Load With and Without MPPT

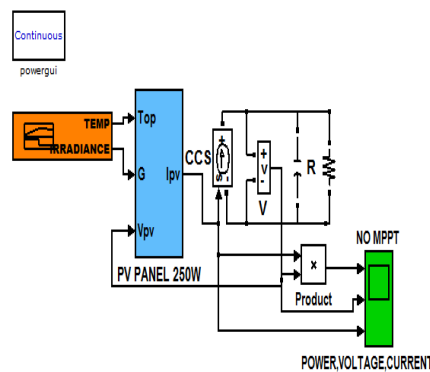

Figure 8: PV Panel Connected Directly To Load

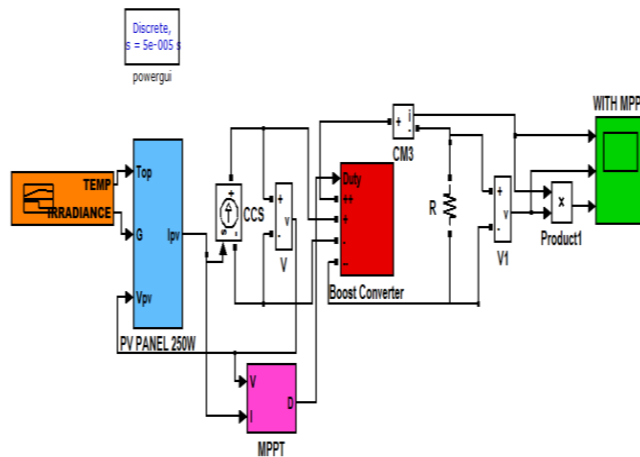

Figure 9: PV Panel Connected To Load With MPPT Controller

Brushless Direct Current (BLDC) Motor

The most commonly used motor for pumping applications is induction Motor or Conventional dc Motor. Because of its rugged construction Induction motor is used in many Industries, Commercial and Domestic applications. Conventional dc motors has superior speed regulating techniques and hence used in many industries [7-11]. The dc motors are generally used for Constant speed applications, lifts, hoists, cranes etc. The major drawback of brushed dc motor is periodical maintenance due to wear & tear of the brushes. As size of the machine increases it suffers from commutation problems. The drawback of conventional dc motor has been overcome by brushless dc motor (BLDC). BLDC motor as the name suggests does not have brushes and has superior performance characteristics similar to Induction motor. Due to elimination of brushes it has the advantages similar to Induction motor and performance superior to Induction motor.

The function of commutator in a conventional dc motor is replaced by Electronic commutation with static switches as shown in the fig 10. Hence BLDC Motor can also call Electronic Commutation Motor (EC Motor). The simulation model of BLDC motor is shown in the fig11. In this work a 1 HP BLDC motor is considered with Photovoltaic system with MPPT. The simulink model of total system is shown in the fig 12

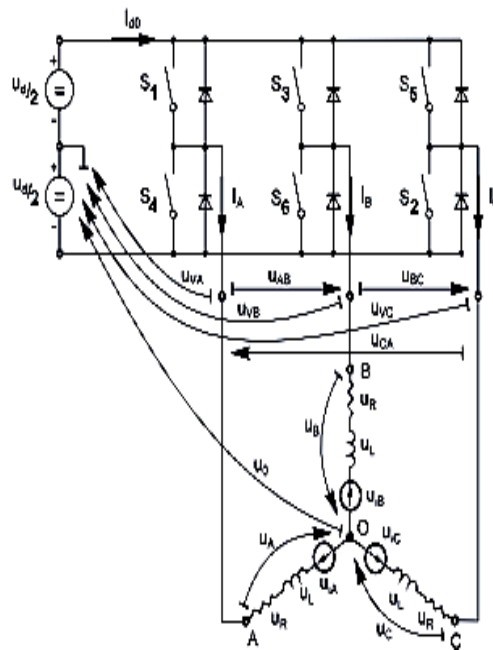

Figure 10: Electronic commutation of BLDC motor

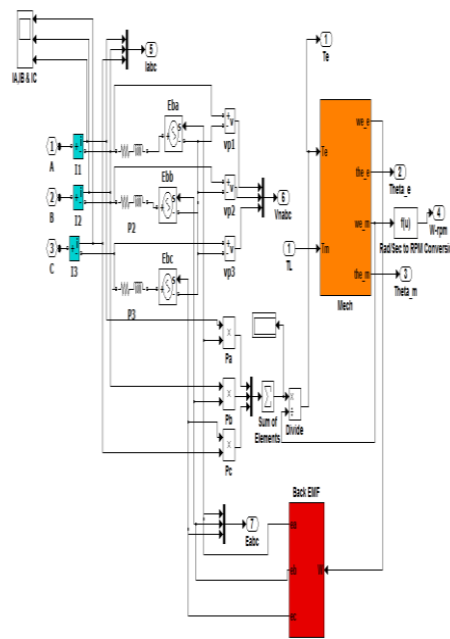

Figure 11: Simulink Model of BLDC Motor

Modeling of BLDC Motor

The equations for phase voltages of a BLDC motor is given by

$$V_a = R \times i_a + \left(L \times \frac{di_a}{dt} \right) + e_a \quad (8)$$

$$V_b = R \times i_b + \left(L \times \frac{di_b}{dt} \right) + e_b \quad (9)$$

$$V_c = R \times i_c + \left(L \times \frac{di_c}{dt} \right) + e_c \quad (10)$$

Where V_a, V_b & V_c are Phase Voltages (V) R & L are resistance (ohm) and Inductance (H)

I_a, I_b & I_c are input currents (A) e_a, e_b & e_c are Back-Emf's of phases (V)

The equations for Back-emf's of the motor

$$e_a = K_w \times f(\theta_e) \times \omega \quad (11)$$

$$e_b = K_w \times f\left(\theta_e - \frac{2\pi}{3}\right) \times \omega \quad (12)$$

$$e_c = K_w \times f\left(\theta_e + \frac{2\pi}{3}\right) \times \omega \quad (13)$$

Where e_a, e_b & e_c are back-emf(V) of phase winding K_w = Back-emf constant of one-phase [V/rad.s⁻¹]

θ_e =Electrical rotor angle. $\theta_e = \frac{p}{2} * \theta_m$ ω =rotor speed [rad.s⁻¹]

θ_m =Mechanical rotor angle

$$\text{Total Torque output (Te), Nm } T_e = \frac{e_a \times i_a + e_b \times i_b + e_c \times i_c}{\omega} \quad (14)$$

The Mechanical part equation is

$$T_e - T_l = \left(J \times \frac{d\omega}{dt} \right) + (B \times \omega) \quad (15)$$

T_l - Load Torque, Nm J - Inertia of rotor and coupled shaft [kgm²]

B - Friction constant [Nms.rad⁻¹] ω - Speed (rpm)

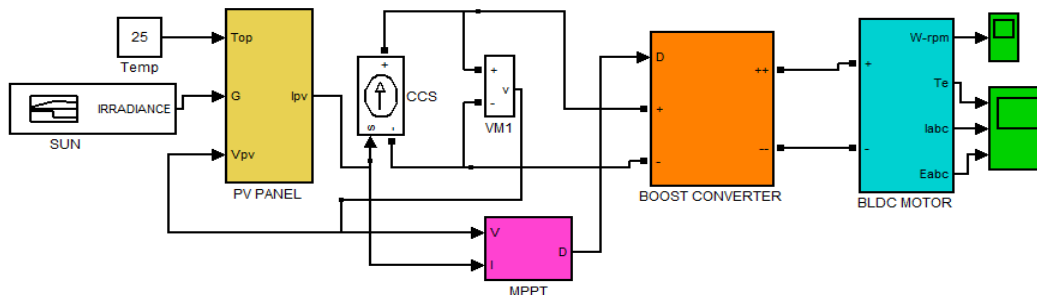

Figure 12: Simulink Model of Total System

Results and Discussions

The I-V and P-V curves of a PV panel may vary with changes in irradiance and temperature as shown in the fig3 and fig13. The changes output voltage, current, power and V_{mpp} with corresponding changes in irradiance and temperature is tabulated below (Table II)

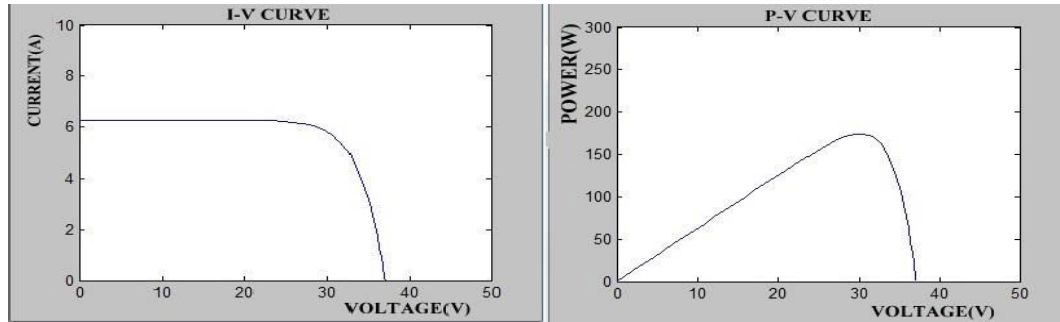

Figure 13: irradiance= 700w/m^2 and temp= $25^\circ\text{Centigrade}$

Table 2: Output characteristics of PV panel with varying irradiance and temperature

Irradiance (w/m^2)	Temp $^\circ\text{C}$	Open circuit Voltage (V_{oc})	Short circuit current (I_{sc})	Maximum Power (P_{max})	Voltage at max power point (V_{mpp})
1000	25	38v	8.95A	252w	31v
800	25	37.45v	7.25A	200w	30v
600	25	36.73v	5.5A	150w	29v
1000	40	36.2v	9A	248w	28v
1000	50	35.02v	9A	230w	28v
1000	55	34.41v	9.1A	225w	26v

From the Table II, it is observed that with respect to changing irradiance and temperature the voltage, current, power & voltage at maximum power point (V_{mpp}) varies. With decrease in irradiance there is a decrease in open circuit voltage, short circuit current whereas with increase in temperature there is an increase in short circuit current, decrease in open circuit voltage.

Considering Irradiance (W/M^2) data (August, Visakhapatnam, Andhra Pradesh, India)

The PV cells are sensitive to atmospheric conditions. A practical irradiance data of changing irradiances and constant temperature is shown in the fig 14(a). The irradiance data is considered as input to simulink model of PV panel connected

directly to R load as shown in the fig8. The response of the system is shown in the fig14 (b)

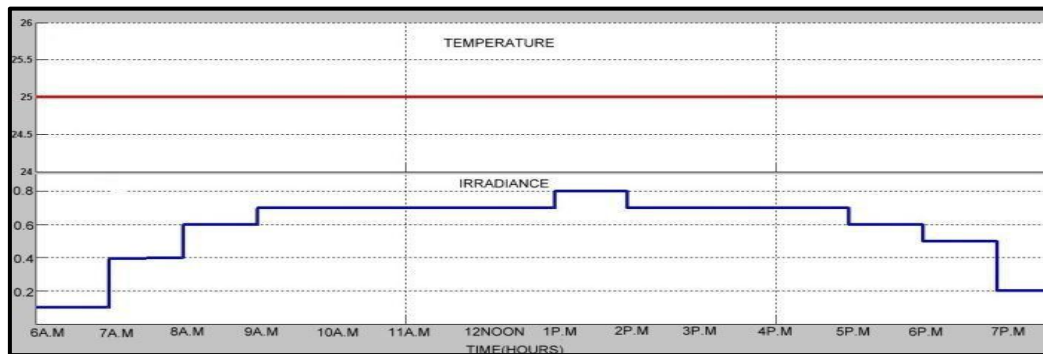

Figure 14 (a): Practical irradiance data of a day and temp=25°C

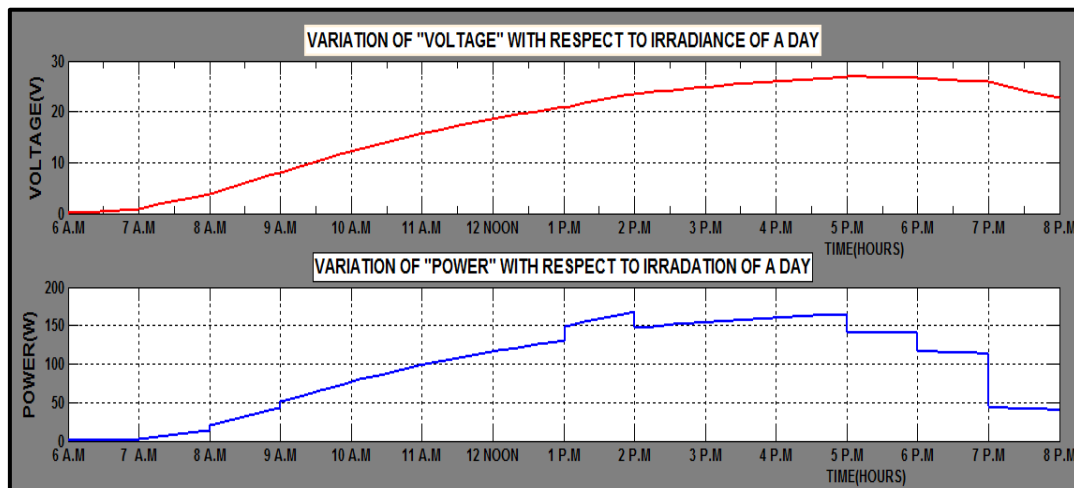

Figure 14 (b): PV Panel Directly Connected to „R“ load

It is observed with change in irradiance the V_{mpp} corresponding to particular irradiance is not maintained constant. During mid-day and noon, the maximum power is extracted from PV panel whereas during remaining time, as the irradiance is low, the power that can be extracted from the panel is low as shown in the fig 14(b). With the obtained output characteristics it is not suitable to drive any load since the source is not continuous. A controller circuit is necessary to drive the load with the available supply.

Fig 9 depicts the simulink model of PV panel connected to R load with MPPT controller. The input data to this system is shown in the fig 14(a). It is observed that with changing irradiance the voltage and power corresponding to maximum power is extracted and maintained as shown in the fig 14(c). From the results it is observed that, the power obtained is continuous and can be connected to a load. The controller

required to maintain continuous power from the output of the PV panel to load is modeled and functions satisfactorily.

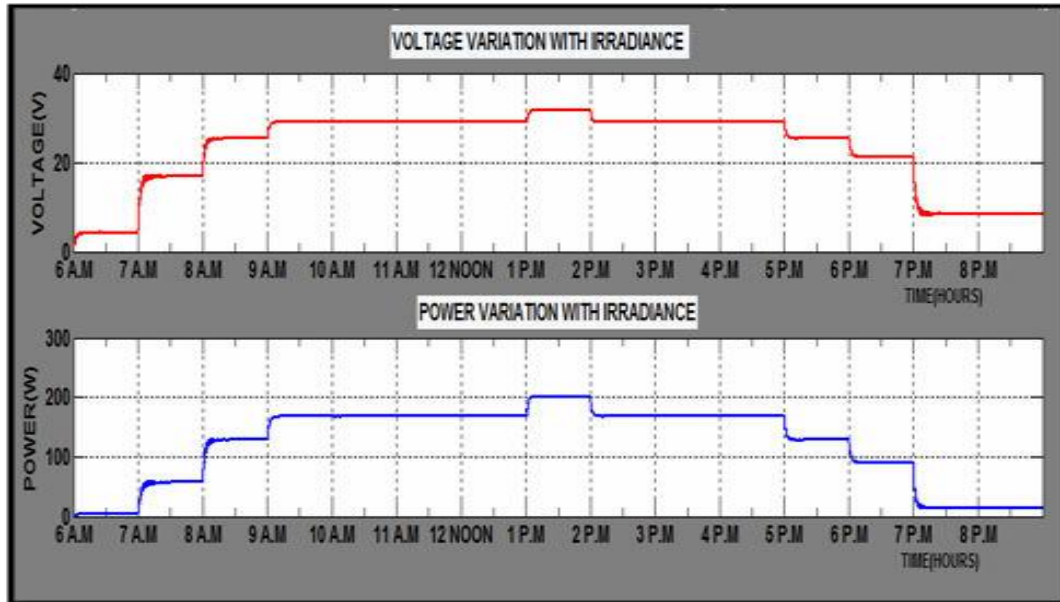

Figure 14 (C): PV Panel Connected to „R“ Load With MPPT (Hill Climbing) Controller

Hill Climbing, Perturb & Observe MPPT With Sudden Variation In Irradiance

Depending on the type of application the algorithm is chosen. For example in applications where it is not necessary to track rapid changes in irradiance Hill climbing MPPT algorithm can be used. Similarly in cases where sudden changes in irradiance has to be tracked Perturb & observe can be used. Two MPPTs are considered for study. The comparison of Hill climbing MPPT and Perturb & observe MPPT is done to determine efficient tracking of algorithm.

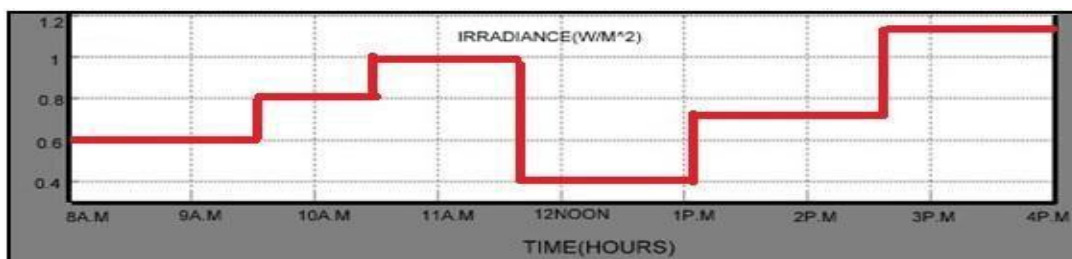

Figure 15 (a): Sudden Changes In Irradiance & Temp=25°C

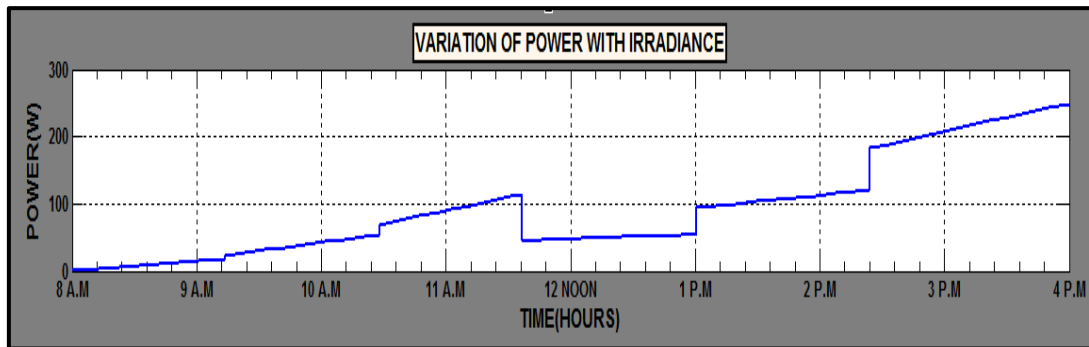

Figure 15 (b): Power obtained with PV Panel connected to load

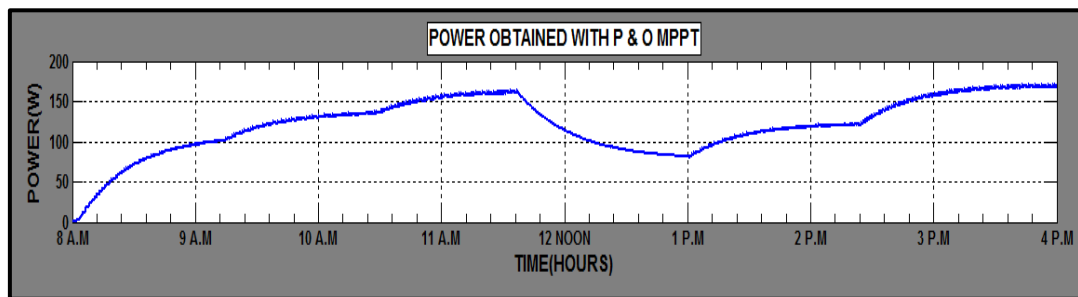

Figure 15: (c): Power obtained when PV Panel connected to load with Perturb & Observe MPPT

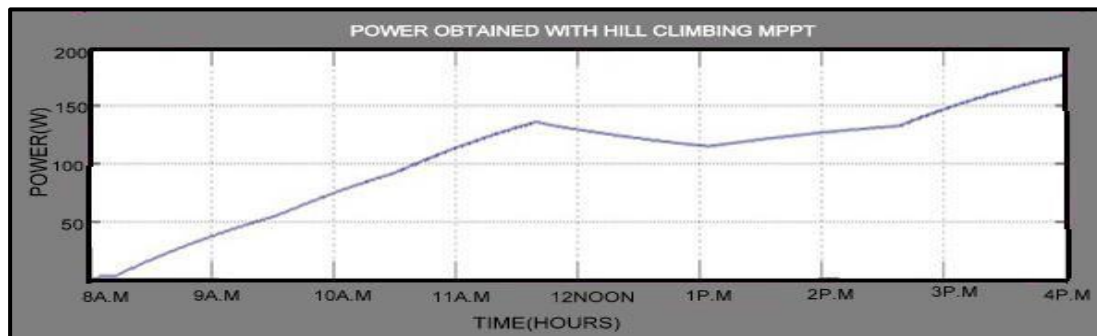

Figure 15 (d): Power obtained when PV Panel connected to load with Hill climbing MPPT

The irradiance data considered is shown in the fig 15(a). It is observed from fig 15(b) the PV panel unable to deliver maximum power when connected directly to load. Fig 15(c) and 15(d) show that with changes in irradiance, the P&O algorithm is able to track the changes and maintain maximum power for particular irradiance whereas Hill climbing algorithm is unable to track rapid changes and maintain power.

Hence P & O is suitable whenever sudden changes in irradiance occurs, hill climbing is used in situations where the necessity to track the power with changes in irradiances become fairly constant.

PV Panel Connected To BLDC Motor With MPPT

The performance of BLDC motor with changing irradiance and constant temperature is depicted in the figures 16(b)-16(f)

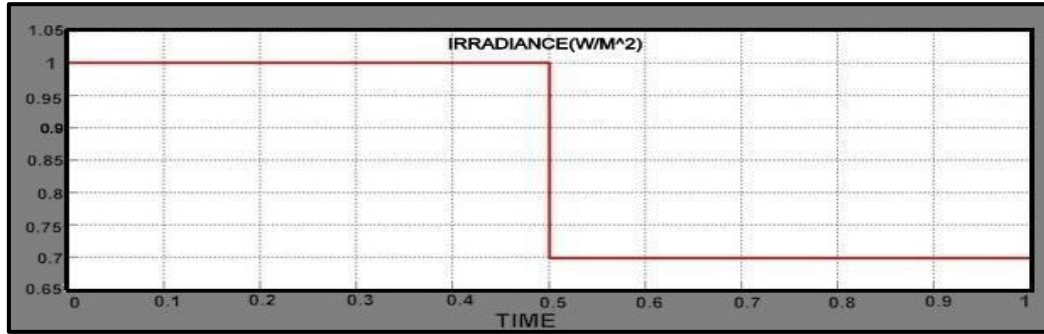

Figure 16(a): Change In Irradiance As Input To BLDC Motor

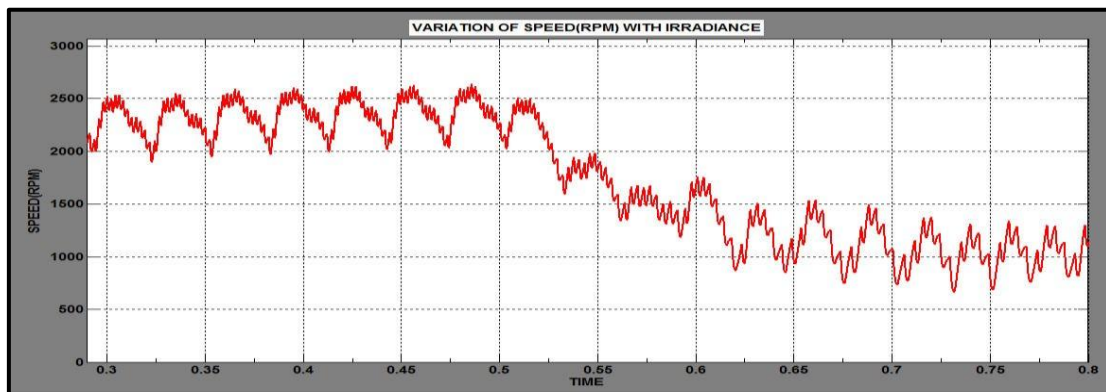

Figure 16 (b): Change in SPEED (rpm) with respect to irradiance

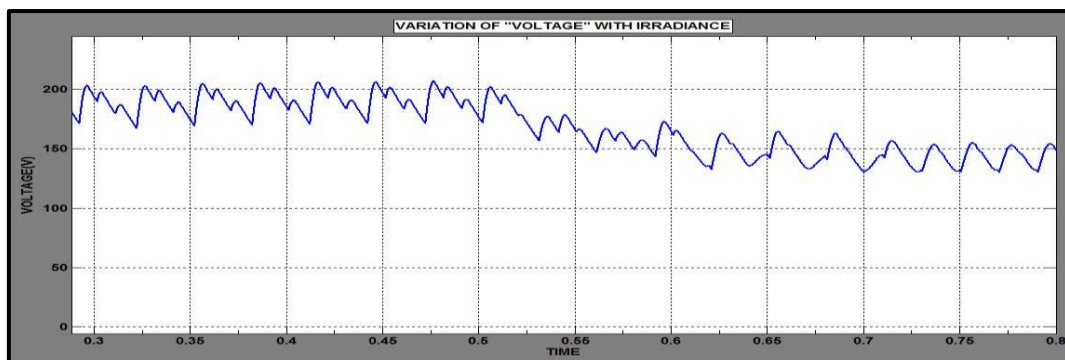

Figure 16(c): Change in VOLTAGE with respect to irradiance

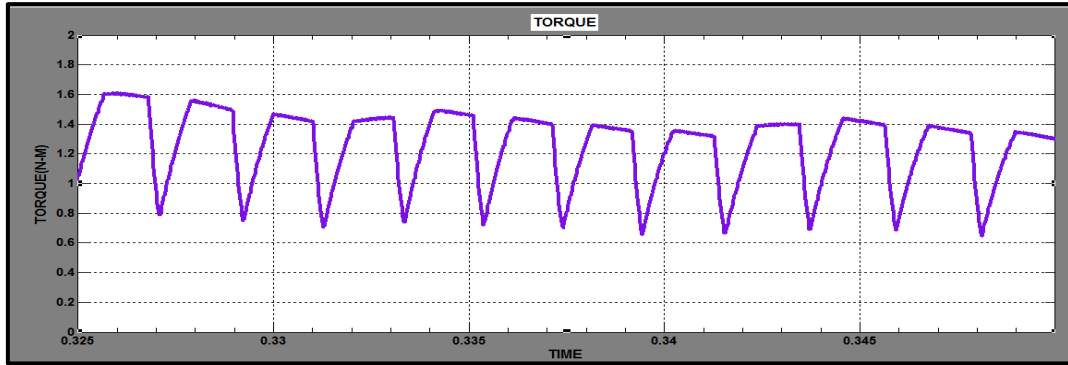

Figure 16(d): Output Torque(Newton-metre) of BLDC motor

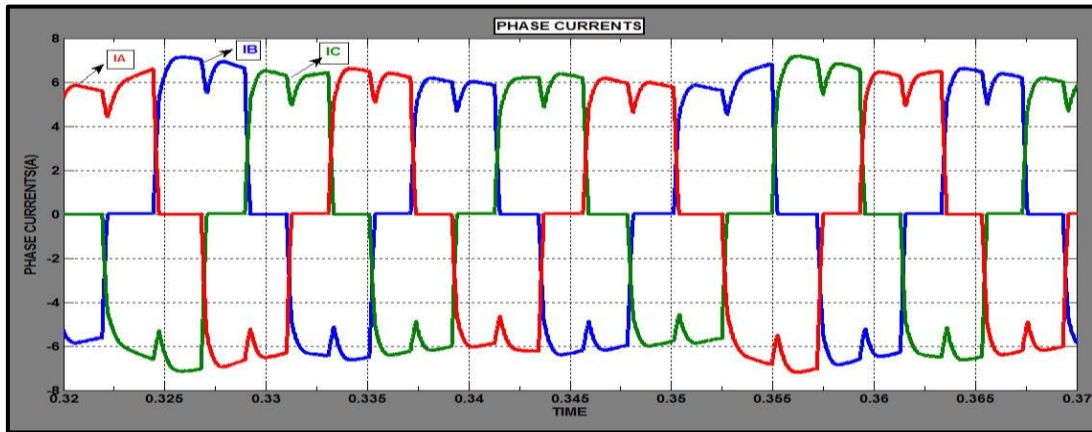

Figure 16(e): Trapezoidal shaped phase currents

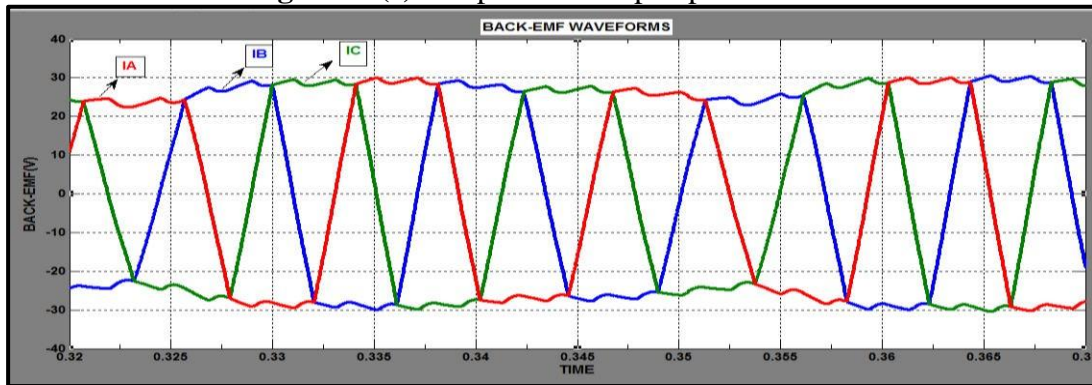

Figure 16(f): Trapezoidal shaped Back-emf waveforms

The irradiance data considered is shown in fig 16(a). It is observed that with respect to change in irradiance there is a corresponding change in speed as shown in fig 16(b), change in input voltage to the BLDC motor as shown in fig 16(c). The torque as shown in fig 16(d) is pulsating because of phenomenon called cogging, ripple. The trapezoidal shape phase currents and back-emf waveforms are shown in

fig 16(e) and fig16 (f). Any attempt to reduce cogging results in more ripples in torque due to deviation from ideal wave shape. Hysteresis or PWM controllers can be used to obtain the rectangular shape of machine currents. Torque is not constant but pulsating due to ripples occurred during switching sequence. In order to maintain constant Torque a Hysteresis Current controller can be used.

Conclusion

In this paper, a comprehensive study of a stand-alone PV system for agricultural application is analyzed. The study includes modeling and simulation of PV fed BLDC motor which can be used for pumping application. The comparative performance analysis of directly connected PV pumping systems with systems using MPPT controller. Accurate modeling of PV cell has been analyzed with simple diode equivalent circuit model. The mathematical model of PV module is an aid to have closer analysis of the variation in output characteristics with perturbation in irradiance & temperature. Hill climbing, perturb & observe algorithms are adopted for MPPT controller. Hill climbing is easy to implement, realize and suitable in situations where dynamic response requirement is not necessary.

The BLDC motor model responds well with changes in irradiance and temperature. It is observed that with changes in irradiance/temperature there is a corresponding change in speed, back-emf and phase currents of the motor. The performance of the PV system with MPPT controller is simulated and verified for a resistive load and for a BLDC motor. MPPT based scheme offers better energy utilization compared to directly connected system.

From the simulation results it is observed that, the performance of modeled PV based pumping systems using BLDC motor working satisfactorily by delivering the torque required to drive the pump.

References

- [1] Malla. S. G, Bhende. C. N, and Mishra. S, 2011 “*Photovoltaic Based Water Pumping Systems*”, Institute of electrical and electronics engineering.
- [2] Pandiarajan. N, Ranganath Muthu, 3-5 JAN 2011 “*Mathematical Model Of Photovoltaic Model Using Simulink*”, International Conference of Electrical Energy Systems,ICEES. Manufacturer Data sheet D M solar, 250w.
- [3] Rashid M.H, 2001, “*Power Electronics Handbook*”, Academic press, London, pp.213-216, chap13
- [4] Ned Mohan, Tore. M. Undel and, William. P. Robbins, 1995 “*Power Electronics converters, Applications and design*” John Wiley & sons, USA, pp.161-178, chap7
- [5] Mohammed Ali Elgendy, Bashar Zahawi, and David John Atkins, October 2010. “*Comparison Of Directly Connected And*

- Constant Voltage Controlled Photovoltaic Pumping Systems*”, IEEE Transactions On Sustainable Energy, **1**, “3”
- [6] Fangrui Lui, Yong kang, Yu Zhang and Shanxu Duan,2008 “*Comparison Of P&O And Hill Climbing Mppt Methods For Grid Connected PV Converter*” *Institute of Electrical and Electronics engineering.*
- [7] Trishan Esham, Patrick L.Chapman, JUNE 2007, “*Comparison Of Photovoltaic Array Maximum Power Point Techniques*” *IEEE Transactions on energy conversion*” **22**, NO,2.
- [8] Krishnan.R, 2001, “*Electric Motor Drives Modeling, Analysis And Control*” Prentice Hall, USA
- [9] Data sheet of Bldc Motor- FCM 8201
- [10] Balogh Tibor, Viliam Fedák, František Ďurovský,2011 “*Modeling and Simulation of the BLDC Motor in MATLAB GUI*” *Institute of Electrical and Electronics engineering.*
- [11] Hamid A.Toliyat, Tilak Gopalarathnam, 2002 “*Ac Machines Controlled As Dc Machines (Brushless Dc Machines/Electronics)*,CRC Press LLC
- [12] Padmaraja Yedamale “*Brushless Dc Motor Fundamentals*”, Microchip Technology.