

Automated Traffic Control System For Emergency Services

M Prasanth¹, G Sai Abhinay², J V N Ramesh³

*¹B.Tech Student, Department of Electronics and Computer Engineering,
KL University*

*²Associate Professor, Department of Electronics and Computer Engineering,
KLEF University.*

*³B.Tech Student, Department of Electronics and Computer Engineering,
KL University*

*mokaprasanth7@gmail.com, g.saiabhi@gmail.com, jvnramesh@gmail.com
Vaddeswaram, Guntur, Andhra Pradesh, India*

Abstract

This paper aims at creating an effective automated traffic control system to prevent ambulances/emergency service vehicles from getting caught up in traffic, there by decreasing hindrances to vital services both in regular and critical situations. The system is implemented by using the Zig Bee wireless communication protocol for wireless communication, IR speed sensors, GPS technology, secure protocols and analytics to create a smart, secure, energy efficient and a cost-effective solution thus making it a practical solution.

Keywords: traffic, ambulance, emergency, automated, wireless sensor networks (wsn),strategic locations.

Introduction

We are much aware of the fact that ambulances and various other emergency services get disrupted by getting caught up in traffic. On an average each ambulance/fire-engine takes over 28 % more time and in the case of cities and urban areas delays could even go as far as up to 1-2 hours regardless of distance to destination. Establishing proper coordination among authorities at all times is neither possible nor feasible, apart from this due to increased dependence on electronic and wireless systems there is the threat of undesired intrusions. Hence a smart, reliable and autonomous traffic control system is required to prevent the loss of many lives/collateral delays[1].

On thorough, systematic evaluation of the problem we made the following observations – ambulances/emergency service vehicles get caught up in traffic due to taking less favourable (e.g. traffic prone) owing to the drivers' lack of knowledgeand

also because those on the roads are unaware/unguided of an ambulance/emergency service vehicle approaching and the actions needed to be taken in order to make way for them.

Design

Through the analysis of the problem it has been decided to solve the problem in two parts- the first part of the problem i.e. drivers' awareness of approaching ambulance/emergency service vehicles and information for necessary measures/actions to be taken is solved by using the RF-Transceivers[2][3] and an additional sensor on the ambulance that transmits its location on the road to nearby traffic-signal posts fitted with systems to react accordingly by warning and diverting traffic to make way for the ambulance/emergency service vehicle.

The communication between the ambulances/emergency service vehicles and device at signal posts is done via RF signals[3] using a secured low-power Zigbee wireless transmission protocol, a technology with proven ease of deployment, functionality and cost-effectiveness.

The second part of the problem i.e. choosing the most favourable route is solved by gathering road-specific and other custom data of traffic conditions from various sensors (IR etc.) fixed at several strategic locations along the roads. The data obtained is then analysed for information and searched for patterns to obtain a list of best routes (represented in colours based on traffic intensity, distance etc.) to guide the drivers at real-time assisted with in-vehicle GPS system.

Module 1:

The first part i.e., system to prevent ambulances/emergency service vehicles from getting caught up in traffic due to fellow drivers' lack of awareness/guidance is realized by using this method. The construction of this module includes two pairs of RF transceivers of different frequencies say TX₁-RX₁-433MHz and another pair say TX-RX₂-836 MHz for communication between signal posts and ambulances/emergency service vehicles[5][6]. By using the two frequency pairs of RF transceivers the protocol will be more secure.

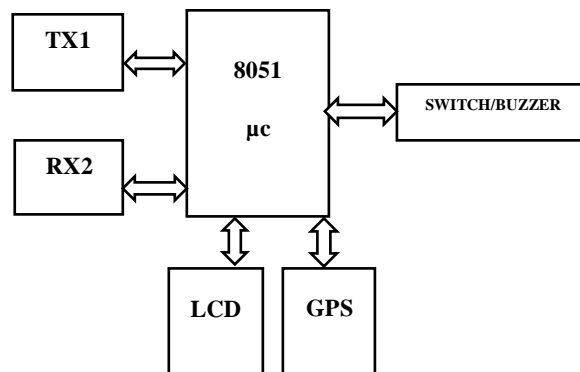

Figure 2.1.1: Module in Ambulance/Emergency Service vehicle

The ambulance module uses one transceiver package say TX₁-RX₂433/836 MHz for sending and receiving signals from traffic post mounted system. The module is incorporated with a LCD to view the map and other details aided by a GPS system, an 8051 microcontroller activated by the switch/buzzer[8]. A12 V DC is supplied to each component of this unit.

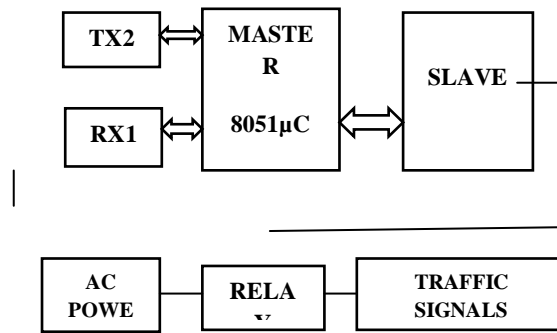

Figure 2.1.2: Module At Traffic Signal Post

The above is the traffic post module which is fitted at the traffic junctions it uses another transceiver say TX₂-RX₁-836/433 MHz for sending and receiving signals between the ambulance and traffic post. The master unit uses an 8051 microcontroller for processing which is connected to the traffic controller that acts as a slave[6].When an interrupt is generated by an emergency vehicle the master unit will disable the slave (traffic controller) and it takes control over the whole action.

Module 2:

The second part i.e., system to help the ambulance/emergency service vehicle driver choose the most favourable route is realised by placing IR/speed [4] sensors at strategic positions and infrared sensors to detect speed of vehicles, traffic intensity all connected by an ad-hoc network[7]. The data is then processed and with analytics the most favourable route is calculated based on the ambulance/emergency service vehicle’s current location obtained through GPS and shown to the driver as routes colour-coded in order of time taken on his on-board device.

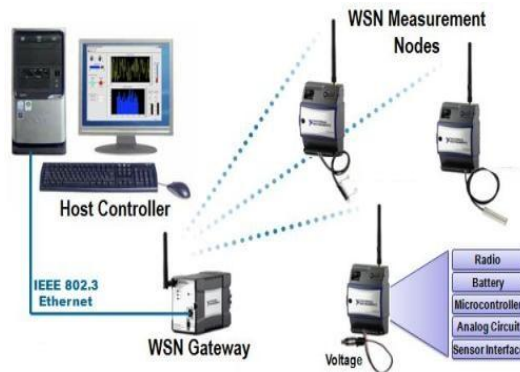

Figure 2.2.1: Data Is Transmitted From All Locations To The Main System

The above setup shows the WSN nodes [11][12] set at strategically located hoardings/traffic posts used to collect data that is sent to the host controller at the control room for further action.

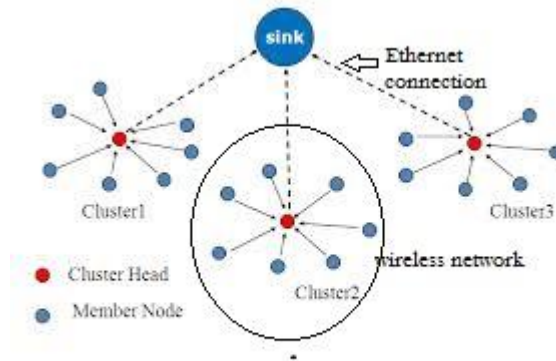

Figure 2.2.2: Establishing Network Connections

The above setup shows the network pattern -various clusters of the WSN nodes[13][14], each member node is a place where sensors are fixed for calculating the speed. The data will be transmitted from all member nodes to the cluster node through wireless network established between them the cluster heads act as a common terminal connected to the WSN nodes via Ethernet connections which are connected to the central point at the control room.

Working:

Implementation The First Module:

The working of the automated traffic control system for emergency services is such that, the vehicle at time of dispatch sends its unique id, location(junction id) and direction in the form of a code word from the ambulance to the system fixed at the traffic posts the microcontroller checks the unique id with the look up tables stored in the memory and checks the junction id when the data bits are matched the authorization is sanctioned and the traffic is cleared according to the direction in which the ambulance is stuck

Using the data other vehicles on the road are affectively guided to make way for the emergency service vehicles by giving appropriate signals.

Apart from this the ambulance/ emergency service vehicle drivers get a mapping of the most favourable routes on their LCD screens with driving instructions.

Coming to the working of the encoding system, the module at the ambulance/emergency service vehicle sends a 16-bit codeword consisting of its unique id, junction id, direction value, parity bits as shown below,

8 bits						4 bits				4 bits			
0	1	1	0	1	0	0	1	1	1	x	x	x	x
Unique code of ambulance/emergency service vehicle						Each junction is assigned by a 4 bit unique value				These are the parity bits.			

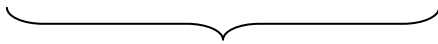

16 bits ie 1 word

This is implemented using acknowledgement based approach

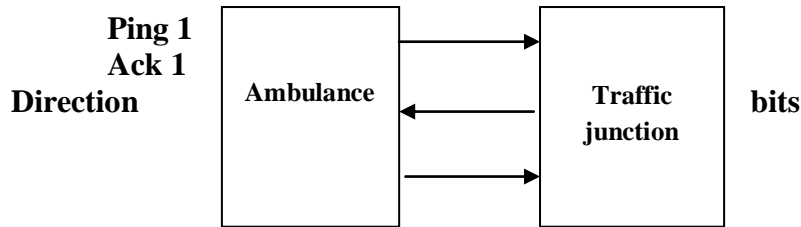
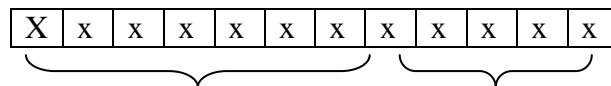

Fig 3.1.1: Protocol Used For This System

Ping1: first the unique ambulance id with the junction’s unique code is transmitted through the rf tx under 433 mhz which is received by the rf rx and process the data bits accordingly and will give the acknowledgement. Depending upon the received acknowledgment the direction bits or the resending(pinging again) are sent to let the system know in which direction it has to clear the traffic or what functionality it has to perform.



Ambulance identification bits + junction + direction bits Identification bits

Ack 1: The ack is based on the output of the processes data if suppose the bits are matched then the ack will be accepting

- 00-Not accepted
- 01-Accepted
- 10-Busy mode

Direction Bits: The direction bits denote the compass directions of the ambulance, such as:

- 00-North direction
- 01-West direction
- 10-East direction
- 11-South direction

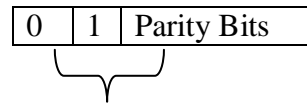

Direction Bits

The direction bits indicate in which road the ambulance has been stuck

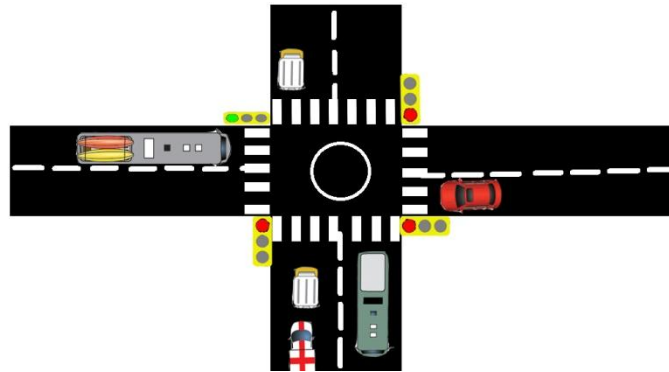

Figure 3.1.2: An Ambulance Stuck In Traffic

The ambulance is stuck close to the junction as the vehicles in front obstruct it due to lack of proper coordination or long traffic jams.

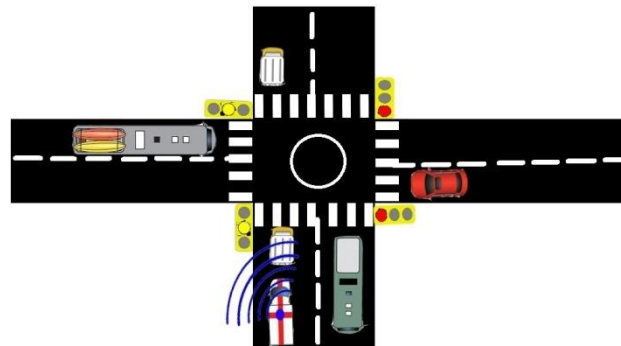

Figure 3.1.3: The Ambulance Signals The System To Make The Road Available

The presence of an ambulance is first detected by the sensor/detector at the junction and communicates with the ambulance after the authorization is sanctioned the route will be cleared automatically without human operation.

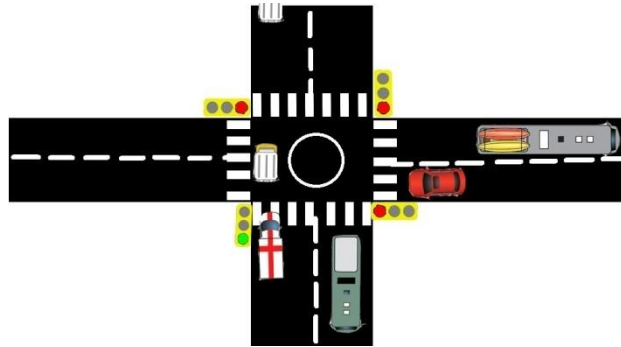

Figure 3.1.4: The Road Is Made Available For The Ambulance As Per Request

Once the authorization is obtained, the path is cleared for the ambulance to move ahead.

Implementation of Second Module

The WSN, IR sensors mounted on strategic locations such as this hoarding.

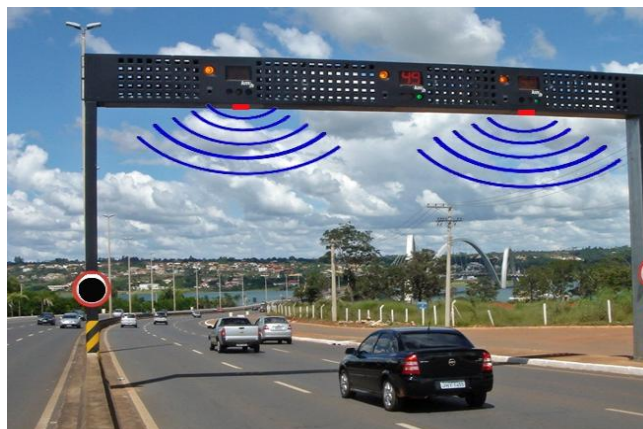

Figure 3.2.1: Infrared sensors fixed to find speed

The system uses IR sensors, located at strategic locations such as traffic signal posts, hoardings etc. to sense the traffic movement.

This collection of data is through a network of clusters containing member nodes and a cluster head to which the data is sent shown in the fig2.2.2. The clusters are connected to a common host network at the control room. The internal and external connections are via Ethernet as shown in fig2.2.1.

As shown above Fig 3.2.1 the WSN, IR sensor pairs are used to calculate speed of moving vehicles, frequency of moving vehicles etc. used to determine the most favourable path.

Speed Calculation:

The speed of moving vehicles is determined by dividing an average car length value

by the time obtained from an IR sensor pair. When ever the beam cuts the timer in the 8051 micro contoller will start and value will be noted till the the beam rejoins

Speed = Avg. Car Length /Time spent by the vehicle b/w IR beams.

The table 3.2shows the theoretical values of traffic intensities and color-coding for routes based on speed of vehicles, traffic intensity. The theoretical values are calculated through statistical observations.

Table 3.2: Theoretical Values

SPEED(KM)	COLOR
>60	Green
40-30	Yellow
<30	Red

The speed of the vehicles moving on a road is found using sensors, the data taken from those sensors are sent to control point and further computations are done on the data acquired to find an average value and is compared with the theoretical value stated in the table 3.1 and the relevant color-coding is given to that road in the maps which can be viewed in the LCD screen by the driver in the ambulance to choose the most favorable route

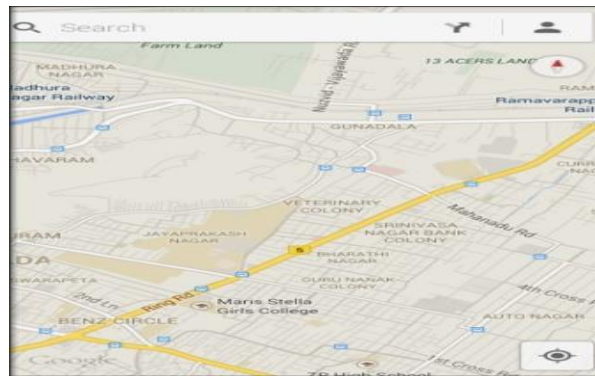

Figure 3.2.2: Display showing the various paths that may be taken

The fig 3.1 above is a screen short of a area of the Vijayawada in the google maps which we have taken as an example to test. These are the maps that we generally get on our smart phones, laptops or a gps systems.

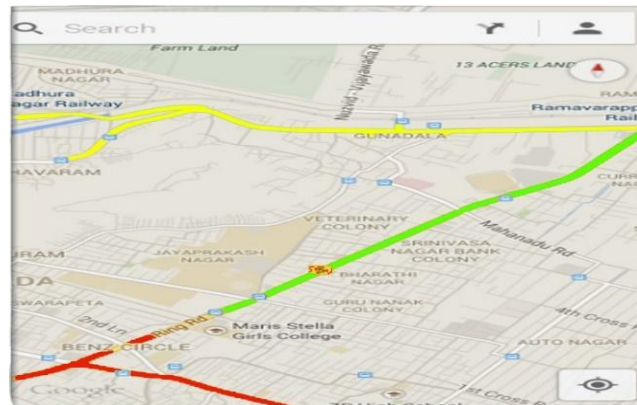

Figure 3.2.3: The display showing paths with colours representing levels of traffic intensity.

In the above fig 3.2 is the similar fig 3.1 with an extra feature incorporated is that it indicates the traffic intensity representing what are the favorable paths for the ambulance to choose avoiding it to get captivated in the traffic.

The roads, colored in green and yellow are the routes that the ambulance has to choose and avoid the red colored routes

Security

Being a vital, heavily used system it has the potential to be manipulated/exploited/hacked by hackers and other anti-social elements. This problem is solved by using fool-proof secure protocols and cryptography while processing signals. The protocol is made more secure and effective by using the encryption algorithm in the system.

The encryption cipher used in a protocol is very important such that even the data is stolen he may not find the patterns to use it . The cipher must be small size, consume less power and provide satisfactory level of security the Tiny Encryption Algorithm (TEA) [9] seems to be optimal block ciphers notable for their simplicity of description and implementation typically a few lines of code and most suitable for implementation in tiny microcontrollers[10].

We have implemented this using 8051 microcontroller which executes instructions in two clock cycles. It has 4 kB -erasable Flash code memory,128-byte RAM data memory, high-accuracy internal RC oscillator and several system-level functions Just perfect for the requirements of low cost, and less power consuming device. When compiled, the cipher occupies 218 bytes of code Decipher needs 224 bytes of code and runs for little more than the encryption.

The protocol itself is much secure its hard penetrate or hack . Moreover, by using this tiny encryption algorithm (TEA), it adds greater benefit for the safety of the system and the whole process like data transmission and communication.

Conclusion

This solution can be used to prevent greatly the interruption of ambulances and other emergency services, ensure in-time reach of emergency services and not to mention it could greatly improve the chances of survival of patients/victims thus preventing irrecoverable or collateral damages as is the case. This is highly effective when implemented in cities and urban areas.

Summary

This is a project with the aim to minimize the time taken by ambulances/VIP/emergency service vehicles in reaching their intended destinations, aiming to prevent deaths and collateral damage due to untimely arrival.

A highly efficient, elegant and cost-effective system has been devised using various advanced, reliable, secure technologies as the solution for the problem discussed.

References

- [1] Rajat & Nirbhay Kumar (2007) "RFID Revolution: Your cars will be tagged", TheEconomics Times, 25 September.
- [2] http://en.wikipedia.org/wiki/Radio-frequency_identification
- [3] http://en.wikipedia.org/wiki/RF_module
- [4] http://en.wikipedia.org/wiki/Passive_infrared_sensor
- [5] The 8051 Microcontroller by Kenneth J Ayala
- [6] Embedded Systems Architecture, Program-ming and Design by Rajkamal
- [7] http://en.wikipedia.org/wiki/Wireless_ad_hoc_network
- [8] http://en.wikibooks.org/wiki/Embedded_Systems/8051_Microcontroller
- [9] http://en.wikipedia.org/wiki/Tiny_Encryption_Algorithm
- [10] Implementation of encryption algorithm for communication by microcontrollers By UDAYAN PATANKAR, S.S.DORLE
- [11] Wireless sensor network by Biswajit Nayak (Regd. No-10IT61B06)
- [12] Wireless Sensor Network Topologies and Mesh Networking , National Instruments(<http://www.ni.com/white-paper/11211/en/>)
- [13] A Comprehensive Review of Cluster Based Energy Efficient Routing Protocols for Wireless Sensor Networks by Naveen Sharma and Anand Nayyar
- [14] Quad Clustering Routing Protocol to Enhance the Stability in WSN by Sharath S.T, Veena N
- [15] http://www.ijesit.com/Volume%202/Issue%201/IJESIT201301_65.pdf
- [16] <http://en.wikipedia.org/wiki/I%C2%B2C>