

Performance of RAKE receiver over different UWB channel

Twinkle V. Doshi

EC Department, BITS Edu Campus, Vadodara, Gujarat, India.

Abstract

In this paper, simplified RAKE receiver structures is analysed and its performance in UWB channels is studied. This paper also contains simulation and comparison of different types of RAKE receivers – ARAKE receiver, SRAKE receiver, and PRAKE receiver. The improvement in the bitrate for the specific distance between transmitter and receiver is shown here. The finger selection is one of the important tasks for the RAKE receiver performance. The selection of the number of fingers is shown with simulation results.

I. RAKE RECEIVER BLOCK DIAGRAM

A RAKE receiver is used to collect multipath components at receiver. The concept of ‘garden rake’ which is used for collecting leaves inspired the RAKE receiver structure. These multipath components are generated due to reflection, scattering and diffraction from various obstacles in the transmission path [1]. When signals arrive at the receiver they are affected with different time delay. The RAKE receiver possesses the characteristic of capturing the delayed signal at different correlators. Output of these correlators is combined to achieve the signal with strong SNR [4].

If the output of RAKE receiver is based on only one correlator, it may give inferior result in terms of BER, as the multipath components possessed by that correlator could have been affected by fading. So a RAKE receiver has multiple correlators. Usually all the correlators will not receive the faded signal at the same time. If the output from one correlator is corrupted by fading, the others may not be corrupted, and through

weighing process corrupted signal can be avoided.

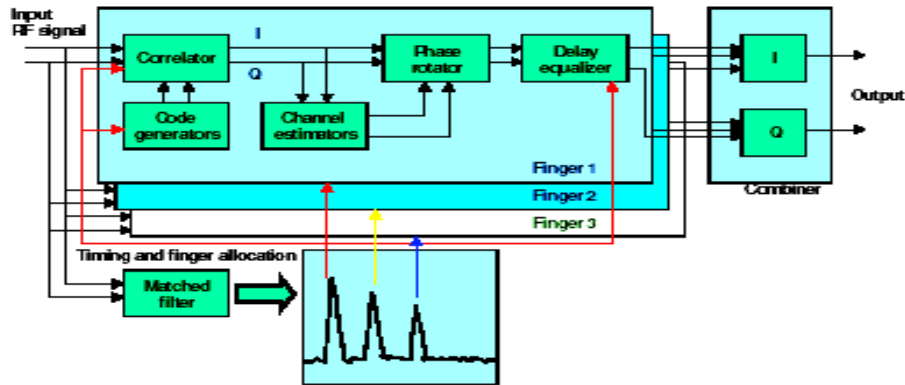

Figure 1 Block diagram of RAKE receiver [6]

RAKE receiver usually consists of correlators, code generator, channel estimator, phase rotator, delay equalizer and combiner. Matched filters, shown in the figure 1, are useful to measure the impulse response of multipath channel. This response generates the channel peaks and gives timing which is useful for successful despreading. Depending on the speed of mobile station and the transmission these peaks are measured and monitored. The number of available RAKE fingers depends on the channel profile and the chip rate. If the chip rate is higher than one, receiver can receive more resolvable paths. But higher chip rate require wider bandwidth. To catch all the energy from the channel more RAKE fingers are needed. Losses and practical implementation problems also increase with higher number of fingers.

II. TEMPORAL DIVERSITY AND THE RAKE RECEIVER

Transmitted signals are always affected with the reflection, refraction and diffraction from the several obstacles in the propagation path. The net combining effect could be constructive or destructive. The destructive effect reduces the signal power. This phenomenon is known as fading. Temporal diversity is used to improve the signal quality in fading channels. The multipath affected received signal $r(t)$ consists of the superimposition of several attenuated, delayed, and eventually distorted replicas of a transmitted waveform $s_m(t)$. When propagation fluctuations within an observation time $T \gg T_b$ and path dependent distortion can be neglected, $r(t)$ can be expressed as follows [2]:

$$r(t) = \sum_j a_j s_m(t - \tau_j) + n(t)$$

where $n(t)$ is the AWGN at the receiver input.

Equation can be rewritten for IR transmissions on the basis of the statistical channel model [2].

$$r(t) = X\sqrt{E_{TX}} \sum_j \sum_{n=1}^N \sum_{k=1}^{k(n)} \alpha_{nk} a_j p_0(t - jT_s - \varphi_j - \tau_{nk}) + n(t) \text{ where:}$$

X is the log-normal distributed amplitude gain of the channel

E_{TX} is the transmitted energy per pulse

N is the number of clusters observed at destination.

$k(n)$ is the number of multi-path contributions associated with the n^{th} cluster.

α_{nk} is the channel coefficient of k^{th} path within the n^{th} cluster.

a_j is the amplitude of the j^{th} transmitted pulse

T_s is the average pulse repetition period

φ_j is the time dithering associated to the j^{th} pulse ($\varphi_j=0$ in the case of DS-PAM)

τ_{nk} is the delay of the k^{th} path within the n^{th} cluster.

The energy contained in the channel coefficients α_{nk} is normalized to unity for each realization of the channel impulse response, i.e.

$$\sum_{n=1}^N \sum_{k=1}^{k(n)} |\alpha_{nk}|^2 = 1$$

Above equation can be rewritten as follows:

$$r(t) = \sqrt{E_{RX}} \sum_j \sum_{n=1}^N \sum_{k=1}^{k(n)} \alpha_{nk} a_j p_0(t - jT_s - \varphi_j - \tau_{nk}) + n(t) \quad \text{where } E_{RX}=X^2E_{TX} \text{ is the total}$$

received energy for one transmitted pulse. Different from the AWGN channel, E_{RX} is spread in time over the different multi-path contributions and can be used by the detector if the receiver is capable of capturing all replicas of the same pulse. The receiver can only analyse a finite subset of N_R contributions, and the effective energy E_{eff} , which is used in the decision process, is smaller than E_{RX} i.e.

$$E_{eff} = E_{RX} \sum_{j=1}^{N_R} |\alpha_j|^2 \leq E_{RX}$$

Replicas generated for the same transmitted signal overlap at receiver with the condition that the time elapsed between arrivals of subsequent signal is smaller than the pulse duration T_M . In this case, signals related with dissimilar paths are not

autonomous, that is, the amplitude of the pulse observed at time t is affected by the occurrence of multi-path contributions arriving immediately before or after time t . The characteristics of the propagation channel suggest that the number of free paths at the receiver depends on T_M . Smaller the T_M , higher the number of independent contributions at the receiver input. This phenomenon is natural in case of UWB as the T_M value is of the order of nanoseconds or a fraction of a nanosecond. This leads to the assumption that all multi-path contributions are non-overlapping, so that the received waveform consists of several independent components. By combining a large number of different and independent replicas of the same transmitted pulse, UWB system takes advantage of multipaths. In this case the receiver uses “temporal diversity” of the multi-path channel to improve performance of the received signal [5].

Performance of the RAKE receiver for propagation over a multipath channel can be evaluated by first assuming a specific model, for the channel impulse response, and then by evaluating the probability of error, in terms of BER as a function of the SNR, for the MRC diversity methods. This analysis is performed under the assumption of exact knowledge of the coefficients of the channel impulse response, or exact channel estimation [2].

The processing overhead increases a lot by considering a RAKE as the receiver. The complexity increases with the number of multipath components analysed and combined before decision [2].

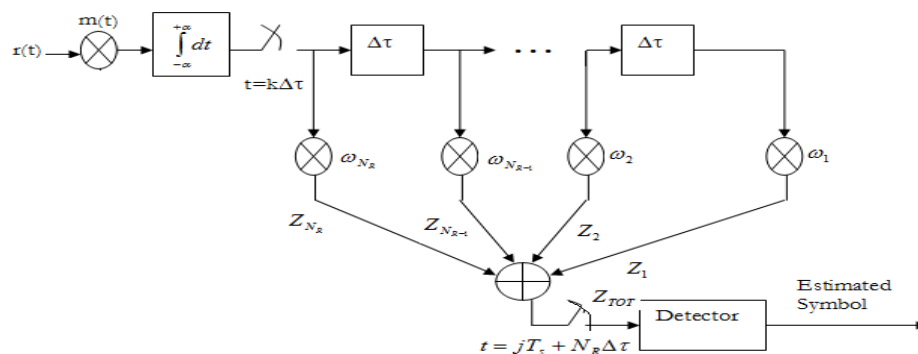

Figure 2 RAKE receiver for discrete-time channel models [2]

The SRAKE receiver examines all multipaths available at receiver and from them selects few best components for combining. The advantage of this method as compared to ARAKE receiver is that number of receiver branch is reduced but still it has to keep track on all multipath components [3]. A second and simpler solution can be obtained by using PRAKE receiver, which combines first few multipath components without worrying about all other multipaths [6]. So processing complexity is reduced considerably. Obviously SRAKE receiver outperforms

PRAKE receiver since it achieves higher SNR at the output of the combiner [7]. The difference in the performance, however, decreases when the best paths are located at the beginning of the channel impulse response as is the case, in general, when considering LOS scenarios.

III. SIMULATION ASSUMPTIONS AND PARAMETERS

Table 1: Simulation parameters for receiver

Parameters	Value
Average transmitted power (dBm)	-30
Sampling frequency (Hz)	10e9
Number of the bits generated by the source	2000
Frame time: average pulse repetition period (s)	32.3e-9
Pulse duration (s)	0.323e-9
Shaping factor for the pulse (s)	0.2e-9
Transmitted signal formats	DS-UWB
Channel model	Standard IEEE 802.3.15a Channel (CM1, CM2, CM3 and CM4)
Length of training sequence	2000
Number of fingers/Number of selected multipath components (L)	10

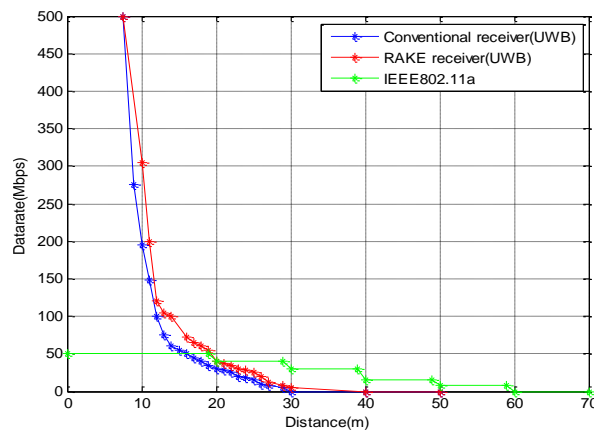

Figure 3 Distance versus datarate plot for conventional receiver, RAKE receiver and IEEE802.11a [8]

UWB offers many advantages over narrowband technology for many applications. Improved channel capacity is major potential advantage of UWB. The UWB may provide significant increase in channel capacity, but only at limited distance. It is used to achieve high data rate communications with 500 Mbps over short distance. Figure 3 compares theoretical UWB data rates of UWB with conventional receiver with one of the today's wireless technologies used in communication applications. This figure also compares the datarate achieved by use of RAKE receiver in UWB instead of normal receiver. [8]

Achievable data rate with the use of conventional receiver is approximately 275 Mbps (shown with blue line in figure 3) for the distance of 10m. UWB implementation requires a receiver capable to exploits multipaths, RAKE receiver is the most suitable and one can achieve the datarate approximately 300 Mbps with the use of RAKE structure (shown with red line in figure 3) for the distance of 10m.

IV. COMPARISON OF DIFFERENT RAKE RECEIVERS

LOS (CM1) channel

The simulation is based on parameters given in table 1. Figure 4 compares the performance of the three RAKE receivers for the channel condition CM1. The best results are obtained with the ideal RAKE receiver. This is because the ideal RAKE receiver considers all multipath components (in this case, 100 multipaths), without taking into account the strength of any multipath component. The SRAKE receive reduces complexity of the receiver by decreasing the number of multipaths. It processes the best few multipath components. The simplest solution is the PRAKE receiver which processes simply the first few multipath components which arrive at the receiver.

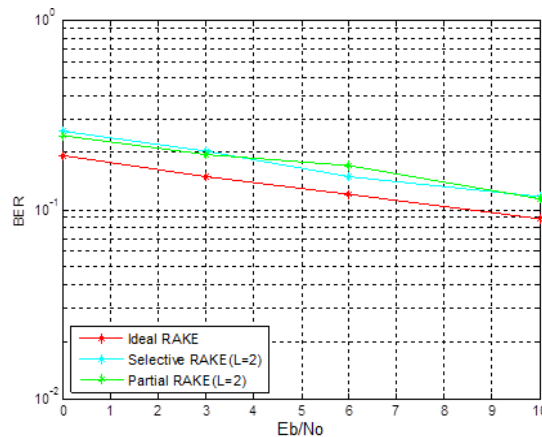

Figure 4 Comparison of ARAKE receiver, SRAKE receiver and PRAKE receiver for L=2 over CM1 channel model

To obtain simulation results the CM1 channel model [2] was considered with a root-mean square (RMS) delay spread of 10.36 ns, an average cluster arrival rate of 0.0233/ns, and an average path arrival rate of 2.5/ns. The cluster decay factor applied is $\Gamma = 7.1$ ns, and the ray decay factor applied is $\gamma = 4.3$ ns. The standard deviation of the fading coefficients chosen is 3.4 dB. The standard deviation of the channel amplitude gain is 3 dB. It is assumed that the transmission rate is such that ISI caused by channel excess delay is negligible. Also, the receiver is assumed to have perfect knowledge of the channel coefficients and delays.

NLOS (CM2) channel

For the following simulations we adopted the CM2 channel model [2] which represents NLOS scenario with a RMS delay spread of 15 ns, an average cluster arrival rate of 0.4/ns, and an average path arrival rate of 0.5/ns. The cluster decay factor applied is $\Gamma = 5.5$ ns, and the ray decay factor applied is $\gamma = 6.7$ ns. The standard deviation of the fading coefficients chosen is 3.4 dB and that of the channel amplitude gain is 3 dB. It is assumed that the transmission rate is such that ISI caused by channel excess delay is negligible. Also, the receiver is assumed to have perfect knowledge of the channel coefficients and delays.

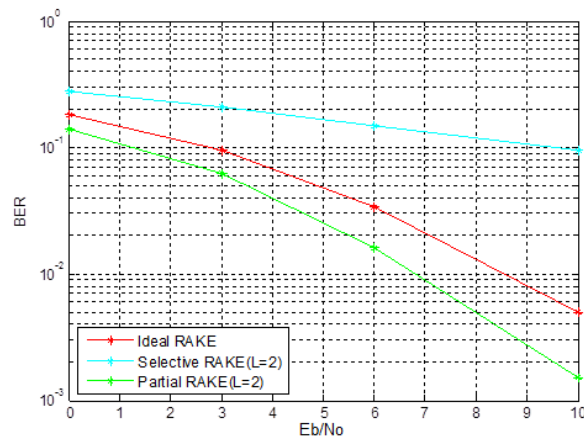

Figure 5. Comparison of ARAKE receiver, SRAKE receiver and PRAKE receiver for $L=2$ over CM2 channel model

Figure 5 shows the simulated performance curves of ideal RAKE receiver or ARAKE receiver (Red line), SRAKE receiver (Cyan line) and PRAKE receiver (Blue line) with the MRC scheme when different number of paths (L) is exploited. Results are summarized in the following table 2.

Table 2 Summary of results for different number of fingers/ multipath components

Sr. No	Channel model	Number of multipath components/Number of fingers	BER of ARAKE receiver	BER of SRAKE receiver	BER of PRAKE receiver
1	CM1 (0-4 m) LOS channel model	2	0.09	0.1	0.1
2		5	0.008	0.01	0.02
3		10	0.025	0.0015	0.015
4		15	0.002	0.002	0.014
5	CM2 (0-4 m) NLOS channel model	2	0.0016	0.005	0.1
6		5	0.025	0.025	0.055
7		10	0.012	0.012	0.04
8		15	0.025	0.03	0.03

V. CONCLUSION

All the multipath components, arriving at the receiver, which are delayed versions of the original signal, contributed somewhat in the final outcome if proper combining technique is used. The ideal RAKE receiver or ARAKE receiver does the same thing; it combines all the multipath components, arriving at the receiver and generates a strong output. But as said earlier, the system becomes too complex as it has to process and combine the all multipath components. Second and somewhat inferior solution is offered by SRAKE receiver. It tracks and scans all multipath components. It finds the strongest five or ten components and combines them to get good result but not as good as that of ARAKE receiver. The third option is the PRAKE receiver which combines first arriving multipath components. So the complexity and processing time is the least in its case compared to that of SRAKE receiver and ARAKE receiver. At the same time the outcome is inferior.

After getting the above simulation results for LOS (CM1) and NLOS (CM2) the results in terms of BER are tabulated in table 2. By observing BER values one can conclude that the ARAKE receiver is the best among all. The BER of SRAKE receiver is less compared to that of the PRAKE receiver. Performance of PRAKE receiver is inferior in both channel conditions. The second conclusion is that the number of fingers could be fixed at 10. With these many number of fingers the PRAKE receiver exhibits good performance. One finger normally receives one multipath components and process it so 10 fingers can gather 10 multipath components.

REFERENCES

- [1] Rappaport, *Wireless Communications Principles and Practice*, Prentice Hall, New Jersey, 1996, pp. 336-338.
- [2] Maria-Gabriella Di Benedetto, Guerino Giancola, "Understanding Ultra Wide Band Radio Fundamentals", Prentice Hall; 1st edition, June 27, 2004
- [3] Mosa Abu-Rgheff, 2007, *Introduction to CDMA wireless communication*.
- [4] M.Z. Win and Z.A. Kostic, "Virtual path analysis of selective RAKE receiver in dense multipath channels," *IEEE Communications Letters*, vol.3, no.11, pp.308-310, Nov. 1999.
- [5] V. Niemela, M. Hamalainen, J. Iinatti and A. Taparugssanagorn, "P-RAKE receivers in different measured WBAN hospital channels," *Medical Information & Communication Technology (ISMICT), 2011 5th International Symposium on* , vol., no., pp.42,46, 27-30 March 2011
- [6] Tommi Heikkilä, "RAKE receiver," S-72.333 Postgraduate Course in Radio Communications, Autumn 2004.
- [7] S. C. Surender and R. M. Narayanan, "UWB Noise-OFDM Netted Radar: Physical Layer Design and Analysis," in *IEEE Transactions on Aerospace and Electronic Systems*, vol. 47, no. 2, pp. 1380-1400, April 2011.
- [8] ETSI TR 101 994-1 V1.1.1 (2004-01), "Electromagnetic compatibility and Radio spectrum Matters (ERM); Short Range Devices (SRD); Technical characteristics for SRD equipment using Ultra Wide Band technology (UWB) Part 1: Communications applications", Technical report, Sophia Antipolis Cedex - FRANCE, 2006.

