

# Performance Evaluation and Validation of Magneto Rheological Fluid Clutch

**K. Hema Latha<sup>1</sup>**

*Assistant Professor, Department of Mechanical Engineering, Muffakhamjah college of Engineering and Technology,  
Banjara Hills, Road No:3, Hyderabad-500034, Telangana, India.  
Orcid Id: 0000-0001-6468-7372*

**Dr. P. Usha Sri<sup>2</sup>**

*Professor and Head, Department of Mechanical Engineering, University College of Engineering,  
Osmania University, Hyderabad-500007, Telangana, India.*

**Dr. N. Seetharamaiah<sup>3</sup>**

*Professor and Head, Department of Mechanical Engineering, Muffakhamjah college of Engineering and Technology,  
Banjara Hills, Road No:3, Hyderabad-500034, Telangana, India.*

## Abstract

Magneto rheological fluids have a wide variety of applications in shock absorbers, vibration dampers and Clutches. Magneto rheological fluid's (MRF) consist of non-Newtonians fluids and are also known as smart fluids for their behavior as their apparent viscosity changes with an application of magnetic field. The MRF offers a wide variation of resistance due to shear. A MRF is obtained by adding micron size ferromagnetic particles to oil or water. This paper presents the design procedure for a replacement to the traditional clutch with a smart device known as Magneto rheological Fluid Clutch (MRFC) and its performance evaluation with respect to the output torque. The Mechanical design parameters are discussed as obtained from the Analysis of simulations results.

The theoretical design is validated with the results obtained from the experimental study on the prototype of MRFC. An experimental test setup has been established to measure the output torque for the performance evaluation of MRFC,

Under various operating speeds (600, 800, 1000,1200, 1400,1600 r.p.m) and control currents (0.0 to 2 A).The performance of the Magneto Rheological Fluid clutch significantly depends upon the magnetic flux density induced between the plates in the fluid flow gap. The theoretical torque transfer capacity of the clutch is predicted utilizing Bingham-Plastic constitutive model. It is observed that there is a correlation between simulation results and experimental results.

**Keywords:** Newtonian fluids, ferromagnetic particles, apparent viscosity, Magneto rheological fluid clutch, Bingham-Plastic Model, Performance evaluation.

## INTRODUCTION

Magneto rheological fluids MR Fluids are known to be controllable fluids as they show change in their rheological behavior. It means their apparent viscosity changes upon the application of an external magnetic field. These MRF are generally non-homogeneous (non-colloidal) suspensions of polarizable micron-sized particles that form chain like structures upon the application of external field [1] as shown in Fig.1.

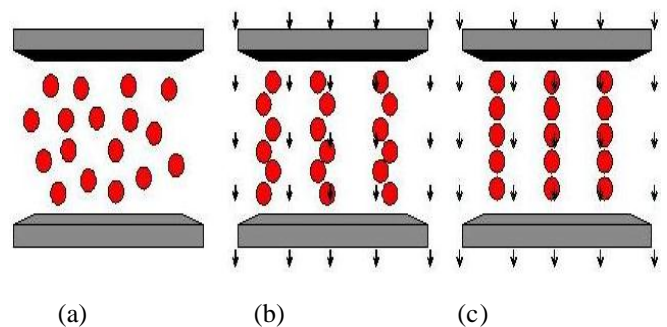

**Figure 1:** Formation of Chain like structures in MR Fluids  
(a) no magnetic field applied; (b) magnetic field applied ;  
(c) Ferrous particle chains have formed.

When a magnetic field is applied, there is a restriction in the fluid flow there by forming a chain structures aligned with the magnetic field line. Before breaking the chains, the MRF behavior is similar to the behavior of a solid. Because of its effect on the apparent viscosity and on the rheological properties, the fractional volume of particles in the fluid depends on the application. For example, the MRF normally

used in clutches have a relatively low fractional volume of particles to minimize the off-state apparent viscosity. A high off-state apparent viscosity is unwanted since it contributes to decrease the efficiency of the system when disengaged. However, the use of a low fractional volume of particles lead unfortunately to a smaller maximal static shear stress, often insufficient for most industrial applications [2]. The smooth operation, simple, excellent control characteristics and advantages becomes an ideal alternative to the car traditional clutch.

MR Fluids can operate at temperatures ranging from -40°C to +150°C. Main characteristics of MRF 132 DG supplied from LORD Corporation is shown in the following table1.

**Table 1:** TYPICAL PROPERTIES OF MRF 132DG

PROPERTY	VALUE
Appearance	Dark Grey liquid
Viscosity @ 40°C (104°F)	0.112 ± 0.02 Pas
Density	2.95-3.15 g/cm <sup>3</sup>
Solids Content by Weight	80.98 %
Flash Point	>150 (>302) °C (°F)
Operating Temperature	-40 to +130 (-40 to +266) °C (°F)
Response time	< milli seconds
Power Supply	2-25 V at 1-2 A (2-50 Watts)
Max Yield stress	50-100kPa (limited by carrier fluids)
Stabilty	Unaffected by most impurities

MR Fluid's composition consists of magnetizable particles (20%-45%), a carrier fluid in addition of various additives. Two factors on which the MR Fluid viscosity is dependent are: the intrinsic viscosity of the carrier fluid and the particle volume fraction.

The variation of Yield stress with magnetic field and the Magnetic Induction (B) Vs. Magnetic Field density (H) of MRF 132 DG are shown in figure 2a and Figure 2b.

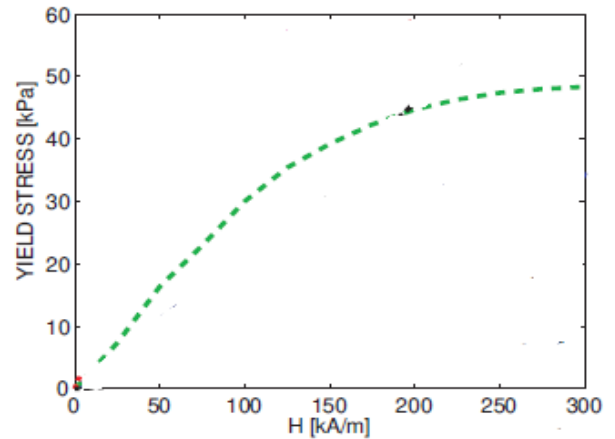

**Figure 2a):** Yield stress of MRF vs. Magnetic Induction

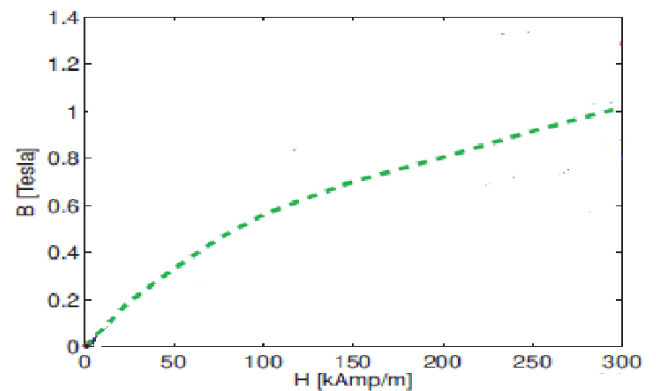
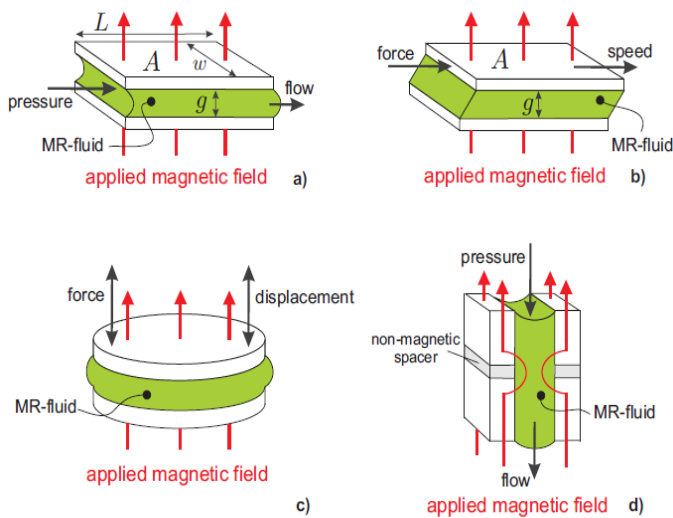

**Figure 2b):** B-H relation of MRF 132DG

This paper mainly describes several aspects of the research work. According to the magneto rheological fluid Bingham constitutive model, relations of mathematical models have been established. Analysis of magneto rheological fluid clutch was done to yield the torque composition. Based on, results obtained from the Magneto static Analysis, i.e., from the magnetic flux densities obtained, at different current inputs, the output torques are calculated. The detailed design procedure and the performance evaluation of the MRFC is presented. Figure 6 shows the detailed experimental set up.

#### OPERATING MODES OF MRFC

There are four different modes in which MRF may be operated . They are valve mode, direct shear mode, Squeeze mode and Pinch mode.This is shown in the following figure 3.



**Figure 3:** operating modes of MR Fluids : a)valve mode, b) Direct shear mode c)Squeeze mode d) Pinch mode

The MRFC consists of two or more parallel plates and operates in shear mode when an external magnetic field is applied perpendicular to the plates. When the fluid is in its relaxed state (i.e. the absence of a magnetic field) the shear

force generated by the fluid is negligible, as it behaves as a fluid similar to motor oil. In this state, the parallel magnetic pole plates are left uncoupled with virtually no force being transmitted across the fluid. With the application of a magnetic field the MR fluid is able to generate considerable shear forces, which can be used to transmit power from one plate to another. One example of this technology can be found in the MR rotary brake system produced by the Lord Corporation. This system can be used for a variety of application including exercise equipment, pneumatic actuators, steer-by-wire systems, and other similar torque transfer applications [3].

### MRFC DESIGN PARAMETERS

In this paper, a description of the research activity using a magneto rheological fluid clutch that allows to control the torque is discussed. To evaluate the performance of the proposed device, a physical prototype was developed and experimentally tested to validate the design process.

An aspect of the present invention, resides in providing a durable magneto rheological fluid clutch with minimized reluctance, embodied in a cost effective design as a solution to the before mentioned drawbacks associated with existing clutch devices. According to this aspect, the solution utilizes controllability of the yield shear stress of a magneto rheological fluid. A magneto rheological fluid clutch according to these aspects preferably includes an input shaft connected with a separately formed input clutch. The input

clutch plate is housed between front and rear covers that contain a quantity of magneto rheological fluid. The front and rear covers support the output element on the input shaft through an axially spaced bearing arrangement for durability.

A magneto rheological fluid clutch according to a preferred aspect of the present invention includes a seal housing carried on the input shaft inside the input clutch plate so that the input clutch plate is fixed on the input shaft through the seal housing. The seal housing has a groove carrying a seal that seals the cavity. In a magneto rheological fluid clutch according to another preferred aspect of the present invention the input shaft has a groove, the seal housing includes a radial bore, and the input clutch plate includes an opening aligned with the radial bore so that a conductor extends to the coil through the groove, radial bore and opening. This provides the benefit of mounting the coil in a rotative manner on the input clutch plate [4].

Preferably, these aspects are further achieved through the input clutch plate's shape, which positions the coil radially away from the center of the clutch to effect increased flux levels. The input shaft from the DC motor is connected to a single input clutch plate. This input clutch plate is enclosed by two output plates in the form of cores on either side. A magneto rheological fluid clutch includes a rotatable input shaft which rotates with an input clutch plate engaged about the input shaft. A bearing supports the housing on the input shaft so that the input clutch plate is rotatable on the input shaft relative to the housing. Magneto rheological fluid is carried in the cavity through which torque is variably transferred between the input clutch plate and the housing. The coil carries a variable electrical current to effect a variable magnetic field across the input clutch plate and through the magneto rheological providing modulated torque transmission between the input clutch plate and the housing [5].

Designing of the structure is done using the Solid works. After initial design, several changes were made prior to the actual fabrication and for the final construction and shop fabrication, drawings were created from the 3D model ensuring accuracy in the final product. Figure 4 shows a cross section of the clutch. The output disk is 39.5 mm (1.55 in.) in diameter and fits inside the outer disk/housing assembly with a 1 mm (0.039 in.) gap on either side for the MR fluid. A stationary electromagnetic coil is placed around the clutch with a steel shell enclosure to direct the magnetic field to the active regions of the clutch. The electromagnetic coil has 750 turns of 18 gauge copper wire. A detail of the MRFC solid model is shown the figure 4. [12]

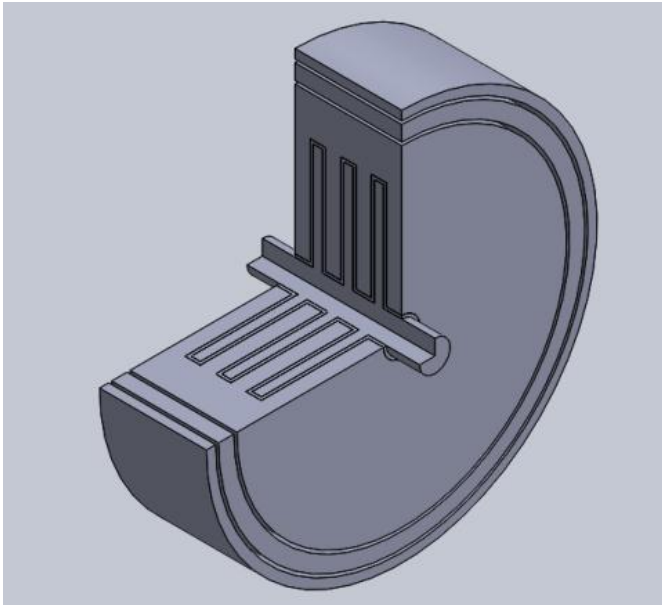

**Figure 4:** A 3-D Solid Model

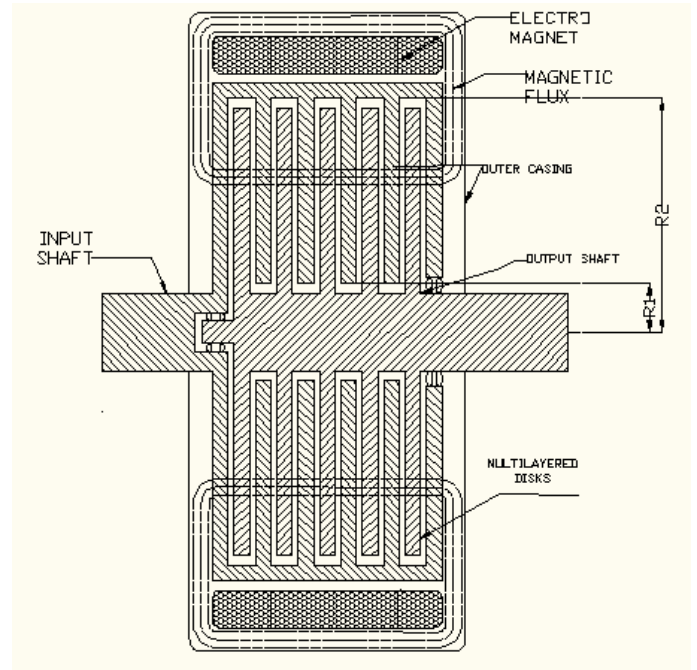

It is important to notice that different materials were used to manufacture the clutch components. The output disk and a portion of the outer disk/housing were made of AISI 1018 steel while the rest of the outer disk/housing was made of AISI 1016. This combination of materials was chosen to direct the magnetic flux from the coil enclosure to the steel portions of the clutch, maximizing the magnetic field strength applied to the MR fluid inside. The magnetic field is concentrated on the outer section of the inner disk, which is the active portion of the clutch. This section has an outer radius of 46.5 mm (1.82 in.) and an inner radius of 17 mm (0.6687 in.). The cross section details of MRFC are shown in figure 5.

### EXPERIMENTAL TEST SETUP

An experimental setup is established to investigate the results i.e the performance of Magneto rheological fluid clutch. The setup is equipped with various parts like DC Drive, DC Motor, clutch, Torsion bar, Load cell, and a data logger unit. Suitable couplings were used to link several components. The torque transmitted to the output shaft is calculated by varying the current flowing through the electromagnet and by varying the input torque to the Clutch using a DC drive of the MRFC.



**Figure 5:** Cross Section of Magneto Rheological Fluid Clutch and its Assembly with Couplings

The Torque for diminishing difference in angular velocity is simply derived as :

$$T_{\min,d} = \frac{2}{3} \pi \tau_{y,d} (R_2^3 - R_1^3) \quad [6]$$

To examine the performance of the MR fluid clutch, the experimental setup shown in figure 6 is designed. The clutch will be characterized for different speed ranges. The clutch is driven by alternating current ac motor with a maximum speed. The dc motor speed is controlled by a dc adjustable frequency drive. A lever arm is attached to the end of the output shaft, which exerts a force on a load cell. [9, 10]

In order to demonstrate the controllability of the MR torque-transfer device, a load cell was used to measure the output shaft torque as well as input shaft torque. To this end, the

measured torque is compared to the desired value in order to adjust the applied electric voltage to the electromagnet. The torque error is defined as the difference between the input torque and the measured torque. [8]

It is important to notice that different materials were used to manufacture the clutch components.

### Speed Control of DC Motor

Speed control means intentional change of the drive speed to a value required for performing the specific work process. Speed control is a different concept from speed regulation where there is natural change in speed due to change in load on the shaft. Speed control is either done manually by the operator or by means of some automatic control device.

One of the important features of dc motor is that its speed can be controlled with relative ease. We know that the expression of speed control dc motor is given as,

$$E = \frac{NP\Phi Z}{60 A}$$

Where, N = speed of motor

P = no. of poles

$\Phi$  = flux (per pole)

Z = number of armature conductors

A = no, of parallel paths

The results are tabulated and graphs are plotted. Therefore speed (N) of 3 types of dc motor– SERIES, SHUNT AND COMPOUND can be controlled by changing the quantities on RHS of the expression. So speed can be varied by changing

- Terminal voltage of the armature V,
- External resistance in armature circuit R and
- Flux per pole  $\phi$ .

The first two cases involve change that affects armature circuit and the third one involves change in magnetic field.

Therefore speed control of dc motor is classified as follows:

- Armature control methods and
- Field control methods.

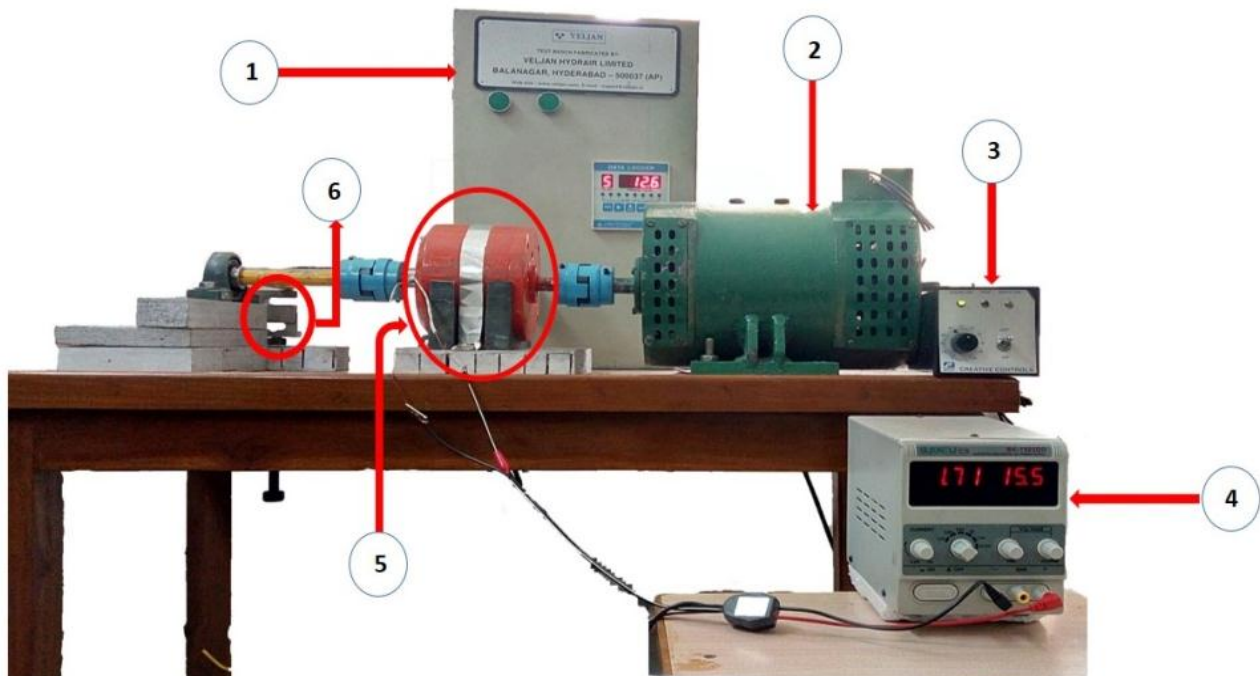

**Figure 6:** Experimental setup 1-Data logger unit; 2-DC motor; 3-DC drive (to control the speed of the DC motor) ; 4-DC drive (to control the current to Electromagnet); 5-MRF Clutch; 6-Load cell

**Procedure**

Before starting the motor, the reading shown on the data logger is calibrated to zero.

- Both the DC drives are turned on i.e., one connected to the motor and another connected to the electromagnet.
- The speed of the motor is set to 600 rpm using the knob on the drive.
- The current flowing through the electromagnet is set to 0 amps using the knob on the drive connected to the electromagnet.
- The corresponding reading of load (in kgf) on the data logger is noted.
- Keeping the speed of the motor constant the corresponding values of load for different currents flowing through the electromagnet are noted.
- The same procedure [7] is repeated for different speeds of motor and corresponding readings are tabulated and performance characteristics of the MRF clutch are plotted and shown in figures 7, 8 and 9.

The Results are tabulated as below:

**Table 2:** Input Torque to MRFC at different motor speeds

Input Current (A)	Input Torque (N-m)				
	600 rpm	800 rpm	1000 rpm	1200 rpm	1400 rpm
0	0.4	0.38	0.3	0.2	0.16
0.5	1.5	1.16	0.82	0.64	0.42
0.75	1.98	1.48	1.16	0.92	0.64
1	2.5	1.84	1.52	1.18	0.92
1.25	2.94	2.24	1.82	1.44	1.14
1.5	3.36	2.56	2.06	1.66	1.38
1.75	3.64	2.78	2.32	1.84	1.56
2	3.92	2.98	2.5	1.96	1.7

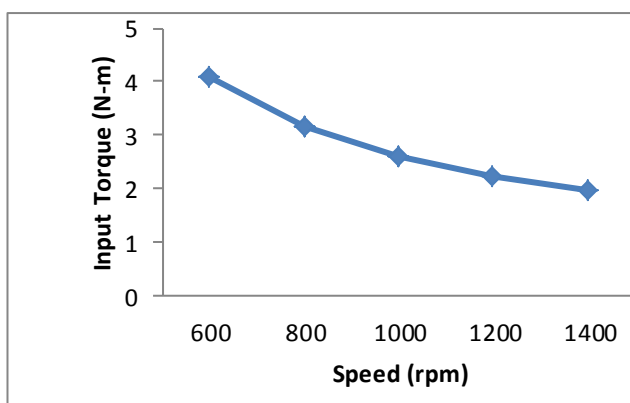

**Figure 7:** Speed Vs Input Torque (N-m)

**Table 3:** Output Torque from MRFC at different input currents at a various speeds

Speed (rpm)	Total Current (A)	Voltage (Volts)	Power (Watts)	Output Torque (N-m)
600	1.22	210	256.2	4.077
800	1.26	210	264.6	3.158
1000	1.30	210	273	2.606
1200	1.34	210	281.4	2.239
1400	1.38	210	289.8	1.976

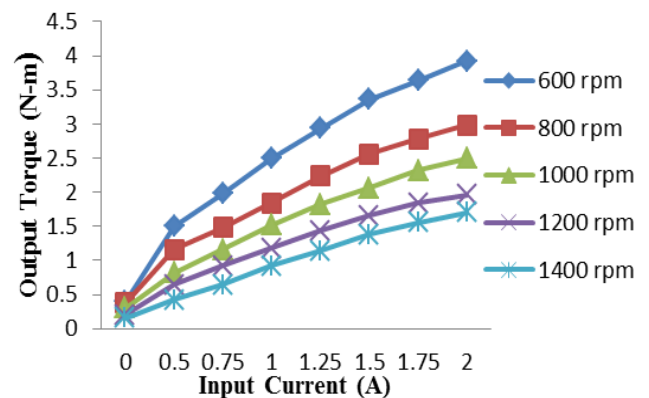

**Figure 8:** Input Current (A) Vs Output Torque (N-m)

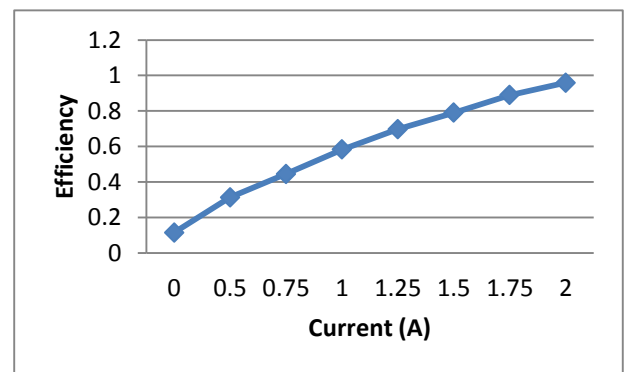

**Figure 9:** Input Current (A) Vs efficiency

**CONCLUSION**

1. To demonstrate the controllability of the MR torque-transfer device, a Load Cell was used to measure the output shaft Torque.
2. The experimental static torque study is conducted to explore the torque output of the prototype of MR fluid Clutch. In this MRFC a commercially available LORD MRF-132 DG is used. The output torque is determined by multiplying the exerted force on the Load cell with the distance from exertion point of the load to the centre of the output shaft.

3. The torque output determined by this method is the maximum torque produced by the clutch, since the static output plate maximizes the shear rate by maximizing the angular velocity difference. The transmitted torque is measured for angular speeds of 600,800, 1000, 1200, and 1400 rpm for input currents up to 2A. The maximum value of the input torque to MRFC is 3.92 N-m for the maximum input current of 2A and output torque from MRFC is 4.07 N-m
4. The operating speed of the clutch does not affect the torque performance, since the viscous torque is relatively small compared to the torque generated by the MR fluid effect. The experimental and theoretical torque output results are compared. The theoretical predictions are in good agreement with the experimental results for various input currents.
5. From the transmitted torque plots, it can be seen that the torque linearly increases with the input currents of up to 2A, which suggests that, the MR fluid itself was still in pre-saturation region and increasing the current further would increase the transmitted torque.

#### ACKNOWLEDGEMENTS

This research work is supported and Funded by Research and development Cell-Seed Funds, Muffakham Jah College of Engineering and Technology.

#### REFERENCES

- [1] Eldhose Baby, Johns.K.Sajan, JerinSaji,AkhilPaul, Arun KR,2015,"A Magneto-Rheological Clutch for Efficient Automotive Clutch,"IJIRSET,Vol.4,Issue 12.
- [2] Lee, U., Kim, D., Hur, N., and Jeon, D., 1999, "Design Analysis and Experimental Evaluation of an MR Fluid Clutch," J. Intell. Mater. Syst. Struct., 10, pp. 701–707.
- [3] W. H. Li and H. Du., "Design and Experimental Evaluation of a Magneto rheological Brake," Int J Adv Manufacturing Technology (2003) 21:508–515.
- [4] Josko Deur, Domagoj Libl and Zvonko Herold, Mathew Hancock and Francis Assadian, "Design and experimental characterization of a magnetorheological fluid clutch", SAE International, 2009.
- [5] Antonio Lanzotti, Fabrizio Renno, Michele Russo, Riccardo Russo, Mario Terzzo,"Design and Development of an automotive magnetorheological semi-active differential", Mechatronics Journal, 24 (2014) 426-435,Elsevier.
- [6] Kavlicoglu, B. M., Gordaninejad, F., Evrensel, C. A., and Cobanoglu, N., 2002, "High Torque Magneto rheological Fluid Clutch," Proceedings of SPIE Vol. 4697, Smart Structures and Materials 2002: Damping and Isolation, pp. 393–400.
- [7] Rocco Rizzo, Antonino Musolino, Francesco Bucchi, Paola Forte, and Francesco Frendo, "Magnetic FEM Design and Experimental Validation of an Innovative Fail-Safe Magneto rheological Clutch Excited by Permanent Magnets," IEEE Transactions On Energy Conversion, vol. 29, NO. 3, September 2014.
- [8] Yalcintas, M., 1999, "Magneto rheological Fluid Based Torque Transmission Clutches," Proceedings of the 9th International Offshore and Polar Engineering Conference, Vol. 4, pp. 563–569.
- [9] Zvonko Herold, Domagoj Libl and Josko Deur,"Design and Testing of an Experimental Magnetorheological Fluid Clutch", Strojarstvo 52 (6) 601-614 (2010).
- [10] BarkanKavlicogluFaramarzGordaninejad, CahitEvrensel, Alan Fuchs, George Korol, "A Semi-Active, High-Torque, Magnetorheological Fluid Limited Slip Differential Clutch", ASME 610 /Vol. 128, OCTOBER 2006.
- [11] K. Hema Latha, P. UshaSri, N.Seetharamaiah," Magneto Static Analysis of Magneto Rheological Fluid Clutch", IOSR Journal of Mechanical and Civil Engineering (IOSR-JMCE), Volume 13, Issue 3 Ver. V (May- Jun. 2016), PP 35-42.
- [12] K. Hema Latha, P. UshaSri, N.Seetharamaiah," Design and Manufacturing Aspects of Magneto-rheological Fluid (MRF) Clutch", 5th International Conference of Materials Processing and Characterization (ICMPC 2016), Science Direct - Materials Today: Proceedings 4 (2017) 1525–1534.