

The High-Precision Positioning System on the basis of Magnetic Shape Memory Alloys

Nikolay Gorbatenko¹ Valeriy Grechikhin², Anastasia Kolomiets³, Ivan Kraevskiy⁴, Artem Kudrya⁵, Danil Shaykhtudinov⁶

¹⁻⁶Platov South-Russian State Polytechnic University (NPI), Prosvescheniya st., 132, Novocherkassk, Rostov region, 346400, Russian Federation.

Orcid: 0000-0003-1049-4801, ²Orcid: 0000-0003-2661-6877, ⁶Orcid: 0000-0002-8629-7217

Abstract

The positioning system is developed in which the distributed magnetizing coil made up of a number of small size coils. The mode of impulse magnetization of active elements from magnetic shape memory alloys (MSMA) is applied with a possibility of magnetic field intensity regulation on the elements. Such approach also allows to realize discrete control mode of MSMA strain and to increase positioning accuracy. The mathematical model for strain assessment of an active element considering permanent strain, nonlinear dependence of strain on the enclosed magnetic field and unevenness of magnetization of an active element is developed. The example of strain modeling of an active element of positioning system is given. Using the mathematical modeling of the three-dimensional electromagnetic field assessment of vortex currents influence on dynamic processes in active elements is carried out, which allows assessing its influence on speed of system positioning. Duration of current impulses in the magnetizing coil is determined. The received results allow solving research problems of properties and use of MSMA in creation of high-speed high-precision positioning systems.

Keywords: positioning system, magnetic shape memory alloys, mathematical simulation, magnetic field, pulse magnetization, strain

INTRODUCTION

The future perspective on new positioning systems is usage of intellectual materials as active elements. Key factor for practical use of such materials is the transformation of one type of energy to another. The magnetic materials with shape memory (magnetic shape memory alloys MSMA) with high sensitivity and potential to change the geometrical sizes in the wide range under the influence of magnetic, mechanical forces and temperature are very promising for such systems. [1, 2]. It allows increasing transformation accuracy, broadening area of movements and simplifying a design of positioning systems. However there are a number of restrictions on application of MSMA as active elements. Such as need of strong magnetic fields application, a magnetic and mechanical hysteresis, considerable influence of temperature

on the MSMA parameters. The difficult nature of the physical processes happening in MSMA and insufficiently developed theoretical base for design lead to the fact that considerable opportunities of these materials are not fully used. The existing researches in this field are generally devoted to development of the devices functioning under the influence of magnetic fields on active elements from MSMA created in magnetic systems with ferromagnetic cores. Prototypes of the actuation mechanisms manufactured with application of MSMA are known [3-6]. It is effective to use local pulse magnetic fields in development of the high-speed high-precision positioning systems with small mass-dimensional parameters for control of active elements from MSMA. It is rational to use the magnetizing coils without ferromagnetic core and to apply pulse magnetization to ensuring the required tension of magnetic field in order to decrease the actuation time and mass-dimensional parameters. Above described issues are considered in this article.

POSITIONING SYSTEM ON THE BASIS OF MSMA

Positioning systems have to provide the required positioning accuracy, high speed, small dimensions and weight. MSMA have the considerable potential for application in these devices due to high sensitivity and an opportunity to change the sizes under the influence of magnetic and mechanical forces. So, the devices made by Adaptamat Inc. (Finland), have the following characteristics: displacement of the active element – up to 5 mm, frequency – up to 1 kHz; maximum strength – up to 1000 N [7]. However successful operation of these devices requires the difficult management system necessary for reduction of influence of a mechanical hysteresis peculiar to MSMA.

In [8] it is offered to apply the push-pull configuration on the basis of two active elements from MSMA allowing using a hysteresis for maintenance of the situation of stability of the mechanical drive without special control and consuming of energy. The following factors have an impact on high-speed performance of this device: time for re-magnetization of the active elements from MSMA, It is necessary to reduce

influence of eddy currents – at a thickness of element less than 2 mm and operating frequency can be higher than 1 kHz [2].

The factor which is also influence the high-speed performance is the magnetic system of the device. To have the maximum strain of the active element it is necessary to create a magnetic field strength about 400 - 600 kA/m. As field hubs the ferromagnetic cores are used [3-9] bringing high inductivity to a magnetic circuit, thereby increasing considerably the reaction time of a device. To cope with this problem it is rational to use the magnetizing coils without ferromagnetic cores, and to apply the impulse magnetization which increases amplitude in coils with the small section of a wire due to low pulse ratio of a current.

Taking into account the considered factors the positioning system realizing a duple configuration is developed where the distributed magnetizing coil consisting of a number of coils of the small size is used and the mode of pulse magnetization of active elements from MSMA is applied with a possibility magnetic field intensity regulation on elements [10].

Such approach allows to realize discrete control mode strain of MSMA and to increase positioning accuracy, to increase speed, to reduce the weight and overall dimensions of system.

Figure 1a presents a block diagram of the device. Figure 1b presents an electrical-kinematic diagram illustrating the principle of its operation. The figures: MC1 – MC12 – magnetizing coils; CS1 – CS12 – magnetization current

switches; CSC – controlled source of current; NI – in-out box; CU – control unit; AE1, AE2 – active elements fabricated from MSMA; DP – displacement pickup; F – flag; I_i – i th coil current; U_1 – line voltage; $N \sim T_p$ – control signal specifying the length of the magnetizing current pulse; signal $U \sim L$ – voltage proportional to the displacement of the actuator drive; signal $U \sim I$ – voltage specifying the level of current in the magnetizing coils.

The device operates as follows. The control program created in the LabVIEW environment specifies the operating mode, the direction of the displacement, the number of magnetization pulses for AE1 and AE2, the length of the current pulses, and the intensity of the magnetizing current in MC1 – MC12 through the NI. These prescriptions are transferred to the control unit CU that forms signals controlling switches CS_i. The current level in CS1 – CS12 is specified by box NI through CSC. The displacement L of flag F connected to drive D is controlled by NI with the help of DP.

Experimental studies were conducted on a test sample of a system. As an active element from MSMA the standard sample made by Adaptamat Inc in form of parallelepiped was used. Its geometrical sizes: length $l = 20$ mm; height $h = 2$ mm; width $b = 1$ mm.

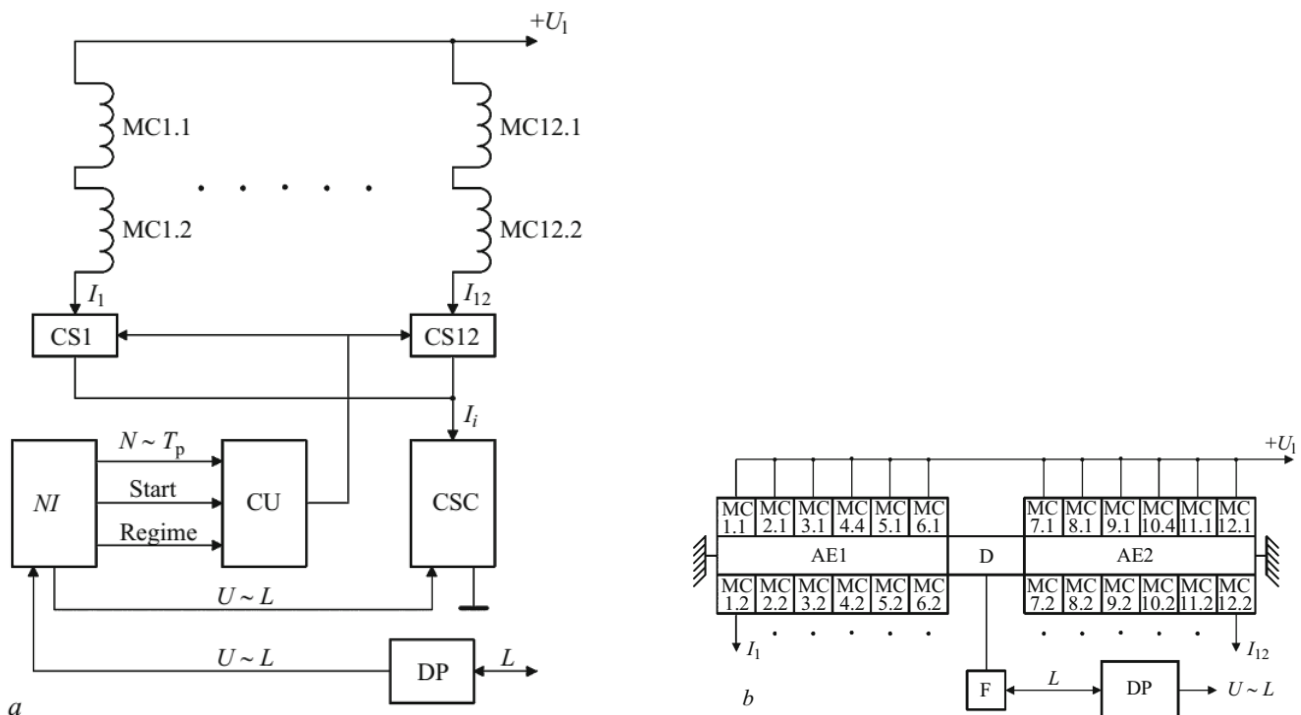

Figure 1: Block diagram (a) and electrical-kinematic diagram (b) of the device

Test sample includes the actuation mechanism and the system of measurement and control of displacement. The actuation mechanism contains two active elements from MSMA constructed on a push-pull configuration and laid on with optic laser sensor of displacement LS5 with six pairs of magnetizing coils. Module of data collection and control of NI USB-6251 is used for receiving and data transfer between the computer, an electronic control unit and the sensor of displacement. Following experimental results were obtained in testing the sample of a positioning system on the basis of MSMA.

In case of anhysteretic magnetization by formation of a pulse sequence $n = 1 \div 1000$ remagnetizing current amplitude $I = 1 \text{ A}$ the linear relocation of the drive caused by strain of the active element from MSMA did not exceed 0,05 mm. In case of magnetization by single pulse of current with an amplitude of 36 A the linear relocation of the drive did not exceed 1 mm. The measurement error on displacement made up not more than $\pm 0,1 \%$; positioning accuracy $\pm 0,01 \text{ mm}$.

Magnetic system of a device presented on a Fig.2. Change of magnetic field intensity on the active element from MSMA is shown on Fig 3. As it is seen on Fig.3 one of peculiarity of distributed magnetization coil usage is nonuniform magnetization of active element from MSMA. For diagnostic and control of strain process the mathematical models were built considering permanent strain, nonlinear dependence of strain on the applied magnetic field and the nonuniformity of magnetization of an active element given below.

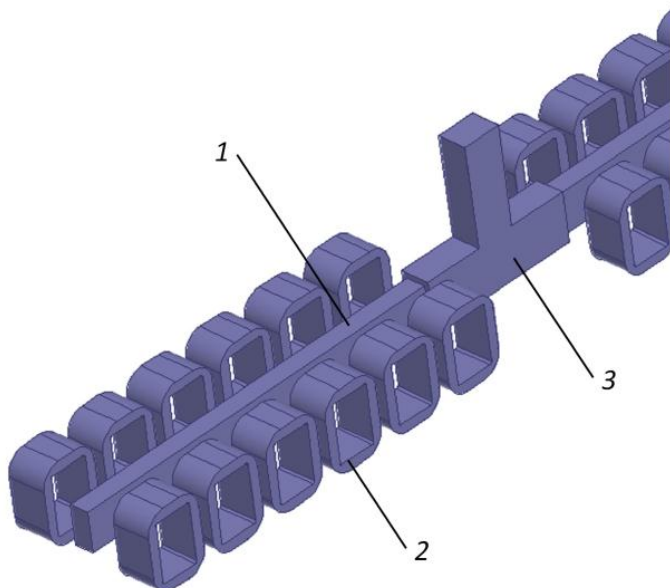

Figure 2: Magnetic system of device: 1 – active elements from MSMA, 2 – distributed magnetizing coil; 3 – drive

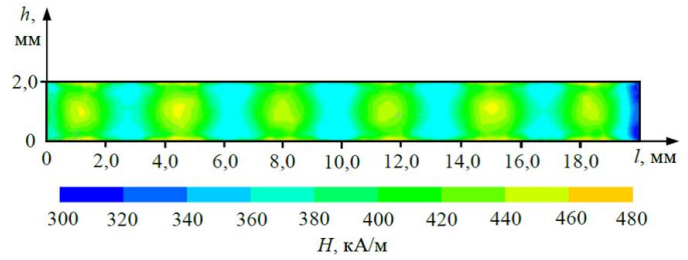

Figure 3: Distribution of magnetic field intensity on the surface of an active element from MSMA

MATHEMATICAL MODELLING OF AN ACTIVE ELEMENT STRAIN ON THE BASIS OF MSMA

The simplified scheme of positioning system drive is shown on fig. 4 where l – not deformed active element from MSMA fixed on one end and operated by the magnetic field set by currents in coils 2. The device is characterized by the following parameters: N – number of coils, L_0 – the full length of not deformed active element, l – length of coverage area of the magnetic field created by the coil, $l \ll L_0$. Length of coverage area of the coil is connected with length of an active element as follows: $l = \kappa L_0$, $\kappa < N^{-1}$.

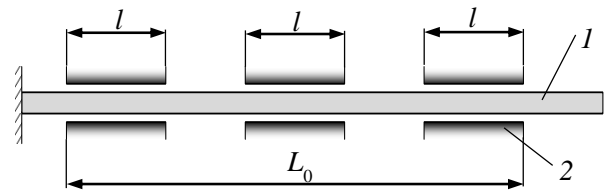

Figure 4: Simplified scheme of positioning system drive

We neglect heterogeneity of magnetic field in a sample in an area of coverage of one coil. It is considered that the sites deformed by influence of magnetic field of any coil don't come into the area of influence of other coils.

The mathematical model considering that strain happens as follows is constructed: for some period Δt the areas of a sample which are treated to action of the field created by coils are extended at the greatest possible size. Lengthening of each of areas at the same time will make λl where λ – the maximum relative strain of an active element under the influence of magnetic field. Relative strain is described by function from coordinate x (coordinate is counted from the place of fixing of an active element) [11]. The active element with permanent strain is represented in fig. 5, the deformed sites are shaded.

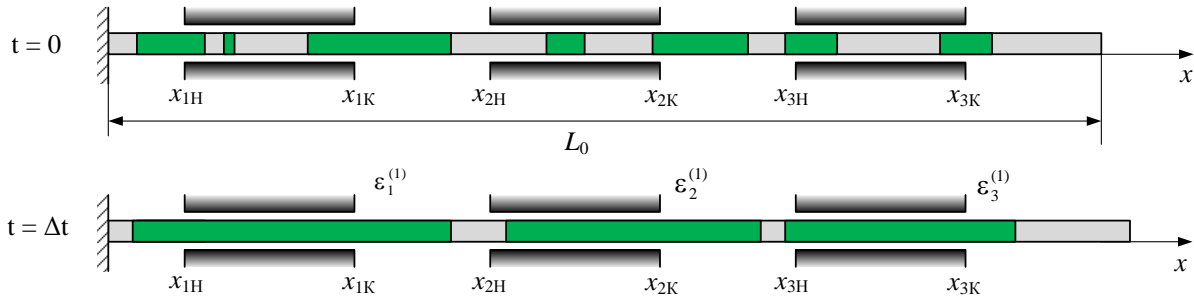

Figure 5: Active element with permanent strain

Strain is defined from expression

$$\varepsilon = \sum_k \delta H_k \cdot \int_0^L \lambda_k(x, H, \varphi(x)) dx,$$

where $\lambda_k(x, H, \varphi(x))$ – function describing unit strain of an active element on k step of magnetic field change; δH_k increment of magnetic field on k step; L – area of active element at which there is a field created by coils. Generally the field is present at all active element, and then tL is equal to AE length on k step of magnetic field change L_k . We will execute modeling of an active element strain positioning system under the influence of magnetic field intensity created by six coils with a help pf developed model.

Dependence of strain from magnetic field intensity $\varepsilon(H)$ is approximated as it is used for magnetic hysteresis of ferromagnetic materials [12]. We use approximated functions:

$$\varepsilon_l(H) = \frac{1}{2} \cdot \varepsilon_m \cdot \{1 + \text{th}[a(H - H_{il})]\},$$

$$\varepsilon_h(H) = \frac{1}{2} \cdot \varepsilon_m \cdot \{1 + \text{th}[a(H - H_{ih})]\},$$

describing the lower and top branches of hysteresis loop respectively. In these formulas ε_m – maximum strain; parameter a defines the steepness of a hysteresis loop; H_{il} и H_{ih} – values of tension of magnetic field corresponding to inflection points of the lower and top branches. The specified parameters are selected from the experimental dependence $\varepsilon(H)$ for this material. Distribution of intensity on length of an active element in the specified system with experimental data is shown in Fig. 6. We will present this distribution with the help of a function rated on unit

$$\varphi(x) = \begin{cases} 1 - \frac{h_1}{2} \cdot \cos \frac{2\pi x}{l}, & L_1 \leq x \leq L_2, \\ 1 - h_1, & x < L_1, x > L_2, \end{cases}$$

where l – distance between centers of coils h_1 – parameter characterizing heterogeneity of the field (for considered system h_1 it makes up about 0,2), $L_1 = x_1 - (l/2)$, $L_2 = x_1 + (N - 1)l + (l/2)$, N – number of coils (in considered case $N = 6$), x_1 – coordinate of the center of the first coil.

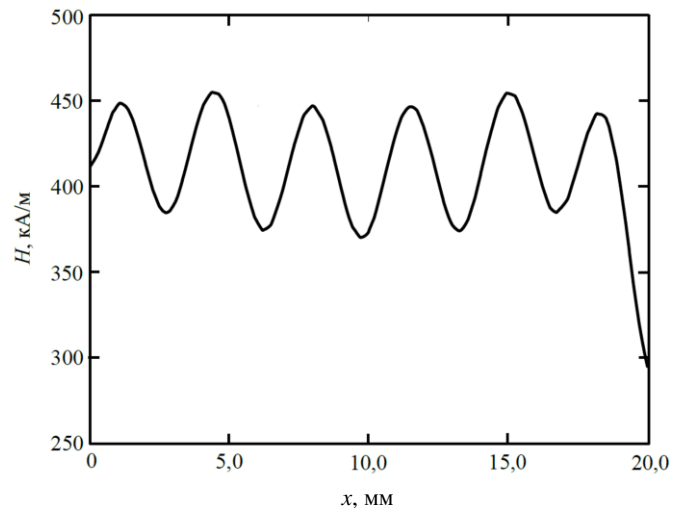

Figure 6: Distribution of magnetic field intensity in active element

Expression for magnetic field intensity in an active element depending on coordinate x is got by multiplication of function $\varphi(x)$ on intensity H_m in an active element corresponding to the centers of coils x_k . Using the approximating functions, we receive expression for distribution of unit strain on sample length without initial strain after the first step of lengthening:

$$\lambda(x, H, \varphi(x)) = \frac{1}{2} \cdot \{1 + \text{th}[a(H_m \varphi(x) - H_{il})]\}$$

Graphs of unit strain dependence on coordinate x_k at various H_m values are presented on Fig. 7, where H_s – intensity of magnetic field saturation of an active element.

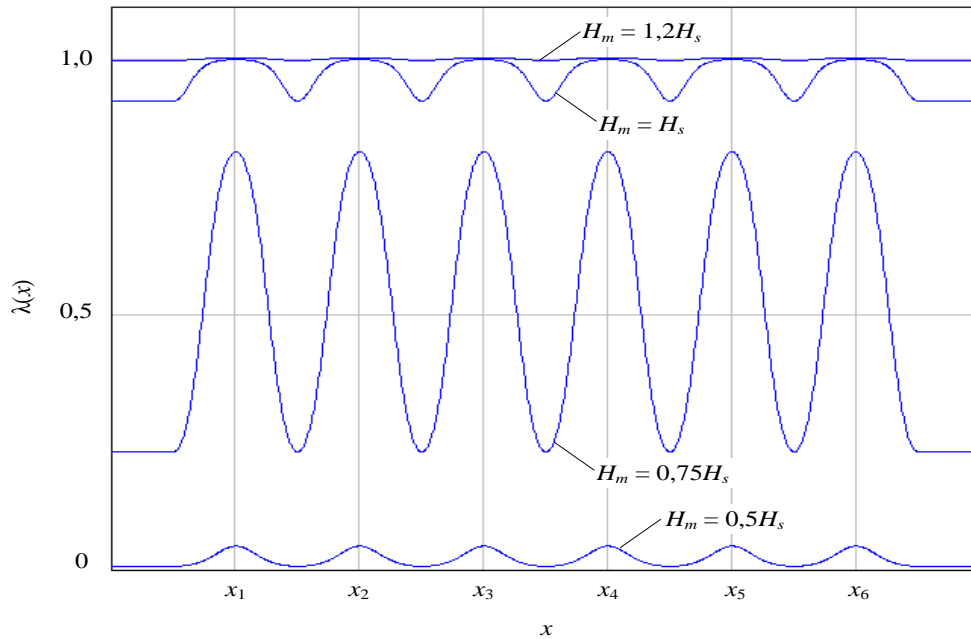

Figure 7: Distribution of unit strain $\lambda(x)$ on length of active element

The model developed in [11] provides simultaneous current feed of the same value in all magnetizing coils; however achievement of high precision determination of an active element strain requires realization of various options current feeds and, respectively, the model describing such options. In this case function $\varphi(x)$ takes a form:

$$\varphi(x) = \frac{1}{m_\varphi} \sum_{k=1}^N H_k e^{-\frac{(x-x_k)^2}{\sigma_k^2}},$$

where x_k – center coordinate of k coil, H_k – rated maximum field value, created by k coil, σ_k – parameter, describing size of influence of k coil, N – number of coils, $1/m_\varphi$ – normalization constant

$$m_\varphi = \max \left\{ \sum_{k=1}^N H_k e^{-\frac{(x-x_k)^2}{\sigma_k^2}} \right\}.$$

Graph of function $\varphi(x)$ for values of parameter $H_1 = 1$, $H_2 = 0,6$, $H_3 = 0,4$, $H_4 = 0,3$, $H_5 = 0,2$, $H_6 = 0,1$, $\sigma_k = 0,3$ ($k = 1 \dots 6$) is shown on Fig. 8. Corresponding graph of unit strain dependence from coordinate (point $x = 0$ corresponds to a point of active element fixing) in cases of different values of current in coils is shown on Fig. 9 (parameter $H_m = 1,2H_s$, where H_s – intensity of magnetic field saturation of active element).

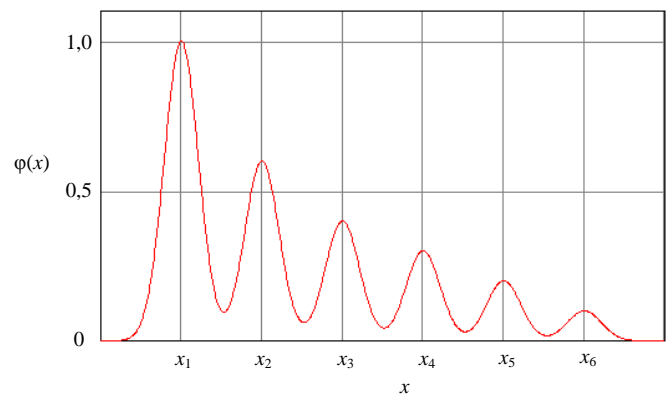

Figure 8: Distribution function of magnetic field in active element

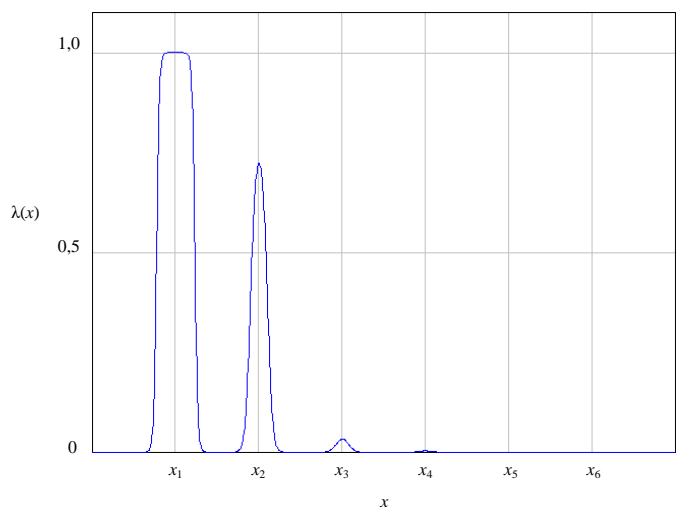

Figure 9: Distribution of unit strain on length of active element

Offered mathematical model allows predicting active element strain of the drive depending on operating current form under the conditions of nonuniform magnetization.

DYNAMIC PROCESSES IN ACTIVE ELEMENT ON BASIS OF MSMA

In developed positioning system the distributed magnetizing coil made up of a number of small size coils. The mode of impulse magnetization of active elements from magnetic shape memory alloys (MSMA) is applied with a possibility of magnetic field intensity regulation on the elements. Using the mathematical modeling of the three-dimensional electromagnetic field assessment of vortex currents influence on dynamic processes in active elements is carried out, which allows assessing its influence on speed of system positioning. We neglect displacement current. Power supply of the device is carried out from a current source.

We will introduce vector magnetic \vec{A} and scalar electric φ potentials. Maxwell combined equations describing the quasistationary electromagnetic field in the considered device transformed with use \vec{A} and φ is written as

$$\text{rot}\left(\frac{1}{\mu} \text{rot}\vec{A}\right) + \gamma\left(\frac{\partial\vec{A}}{\partial t} + \text{grad}\varphi\right) = 0;$$

$\text{divgrad}\varphi = 0$ in volume of ferromagnetic elements from MSMA;

$$\text{rotrot}\vec{A} = \mu_0\vec{\delta} - \text{in magnetizing coils};$$

$$\text{rotrot}\vec{A} = 0 - \text{in surrounding space},$$

where γ – unit electric conductivity of ferromagnetic elements; δ – current density.

On interface regions with various magnetic permeability it is necessary to provide equality of normal components of magnetic induction and the tangent components of magnetic field intensity expressed through \vec{A} . The above described system has to be complemented with initial conditions for \vec{A} in ferromagnetic elements and boundary condition on surfaces of ferromagnetics

$$\frac{\partial\varphi}{\partial n} = -\left(\frac{\partial A}{\partial t}\right)_n.$$

Solution of the given equations system was carried out by a finite element method. Calculation domain with artificial border was filled with tetrahedrons. Current density in coils was set up in the form of step function. After definition of nodal unknown the magnetic induction, magnetic field intensity and density of eddy currents were calculated in tetrahedrons

$$\vec{B} = \text{rot}\vec{A}; \vec{H} = \frac{1}{\mu} \vec{B}; \vec{\delta}_v = -\gamma\left(\frac{\partial\vec{A}}{\partial t} + \text{grad}\varphi\right).$$

Computing experiments were carried out with following basic data: active elements – Ni_2MnGa alloy with specific electric conductivity $\gamma = 1.65 \cdot 10^8$, magnetic permeability $\mu = 100\mu_0$; sizes of elements $1 \times 2 \times 20$ mm; form and size of magnetizing coil segment is shown on fig. 10.

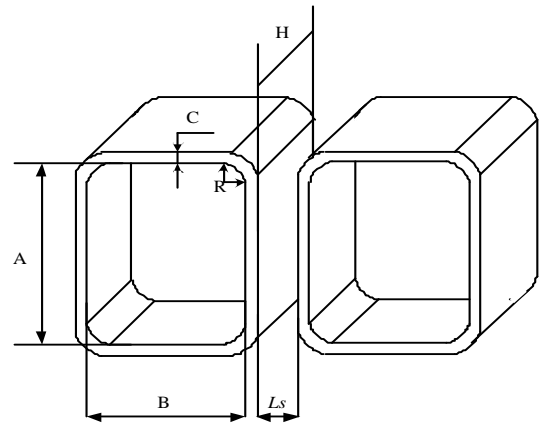

Figure 10: Form and size of magnetizing coil segment:
 $A = 3$ mm; $B = 2$ mm; $C = 0,5$ mm; $H = 2$ mm; $L_s = 0,5$ mm;
 $R = 0,2$ mm

Graphs of current change in time in magnetizing coil and magnetic field intensity in an active element were obtained in results of modelling. (fig. 11).

Analysis of the obtained results shows that for considered active element time of delay of magnetic field due to influence of eddy currents is about 0.2 ms. In this regard it is possible to draw the following conclusion: influence of eddy currents of elements should be considered when duration of current impulses in the magnetizing coil doesn't exceed 0,5 ms.

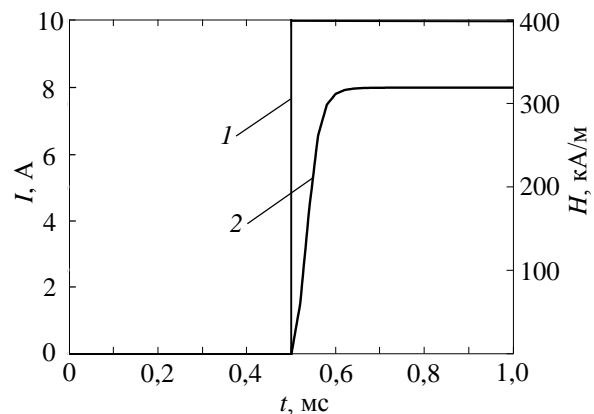

Figure 11: Graphs of current change in time in coil (1) and magnetic field intensity in an active element (2)

DISCUSSION

Carried out research has shown that application of active elements on the basis of MSMA with deformation potential under the influence of magnetic field allows to provide considerable linear movement. Unlike the known analogs, in the offered positioning system the distributed magnetizing coil made up of a number of small size coils is used. The mode of impulse magnetization of active elements from magnetic shape memory alloys (MSMA) is applied with a possibility of magnetic field intensity regulation on the elements with the aim of speed response increase and decrease in its overall dimensions and weight. Such approach allows realizing discrete control mode of actuation mechanism drive and to increase the accuracy of its positioning. Mathematical models for definition of an active element strain in the conditions of its nonuniform magnetization are offered. Application of models allows considering an initial condition of an active element on the basis of MSMA and its permanent strain in order to increase accuracy of positioning. Numerical modeling of transition processes in the electromagnetic system of positioning allows to execute assessment of eddy currents influence in the active MSMA elements, on dynamic processes in active elements and, as a result on speed of positioning system. Influence of eddy currents should be considered when duration of current impulses in the magnetizing coil doesn't exceed 0,5 ms.

The obtained results allow solving essentially new research problems of MSMA use in development of high-speed high-precision positioning systems. The possibility of such tasks solution expands a scope of perspective intellectual materials application in a wide range of complex mechatronic systems.

ACKNOWLEDGEMENTS

The study results are obtained with the support of the project #2.7193.2017/8.9

"Development of scientific bases of design, identification and diagnosis systems for highly accurate positioning with application of the methodology of inverse problems of electrical engineering", carried out within the framework of the base part of State job.

REFERENCES

- [1] Vasil'ev, A.N., Buchel'nikov, V.D., Takagi, T., Khovailo, V.V. and Estrin, E.I., 2003, "Shape memory ferromagnets", *Phys. Usp.*, 46, pp. 559-588.
- [2] Wilson, S.A., Jourdain, S.A., Zhang, Q. and et al., 2007, "New materials for micro-scale sensors and actuators: an engineering review", *Materials Science & Engineering R-Reports*, 56(6), pp. 1-129.
- [3] Asua, E., Feuchtwanger, J., Garcia-Arribas, A., Etxebarria, V., Orue, I. and Barandiaran, J.M., 2009,

"Ferromagnetic shape memory alloy actuator for micro-and nanopositioning", *Sensor Letters*, 7, pp. 348-350.

- [4] Riccardi, L., Naso, D., Turchiano, B. and Janocha, H., 2012, "A precise positioning actuator based on feedback-controlled Magnetic Shape Memory Alloys", *Mechatronics*, 22(5), pp. 568-576.
- [5] Schiepp, T., Pagounis, E. and Laufenberg, M., 2014, "Magnetic shape memory actuators for fluidic applications, International Fluid Power Conference (IFK), Aachen, Germany, March 24-26.
- [6] Wang, F.-X., Li, W.-J., Zhang, Q.-X., Wu, X.-J. and Ge, C., 2005, "Design and control of linear actuators made by magnetically controlled shape memory alloy", *IEEE International Conference on Mechatronics*, July 10-12, pp. 583-586.
- [7] Suorsa, I., Pagounis, E. and Ullakko, K., 2004, "Magnetic shape memory actuator performance", *Journal of Magnetism and Magnetic Materials*, 272, pp. 2029-2030.
- [8] Hubert, A., Calchand, N., Gorrec, Y. Le. and Gauthier, J.-Y., 2012, "Magnetic shape memory alloys as smart materials for micro-positioning devices", *Adv. Electromagn.*, 1(2), pp. 75-84.
- [9] Shaykhutdinov, D., Gorbatenko, N., Grechikhin, V., Shirokov, K., Dubrov, V., 2015, "Development of the Computer-Based Stand for Research of the Voltage Generation Effect of the Magnetic Shape Memory Material", *RJAS*, 10(4), pp. 170-172.
- [10] Gorbatenko, N.I., Grechikhin, V.V. and Shaikhutdinov, D.V., 2015, "Measuring and Actuating Devices Based on Shape Memory Ferromagnets", *Metal Science and Heat Treatment*, 56, pp. 609-613.
- [11] Grechikhin, V.V., Lozin, O.I., Kudrya, A.V., Kudrya, N.A., Shaikhutdinov, D.V. and Yanvarev, S.G., 2014, "Mathematical modeling of strain of active element magnetic shape memory actuators", *Fundamental research*, 4 (11), pp. 744-748.
- [12] Bozort, R., 1956, "Ferromagnetizm", Moscow: Izd-vo inostr. lit.